

Inferior parietal lobule function in spatial perception and visuomotor integration

RICHARD A. ANDERSEN | *Salk Institute for Biological Studies,
San Diego, California*

CHAPTER CONTENTS

Lesion Studies	
Lesions in humans	
Attentional deficits	
Constructional apraxia	
Visual mislocalization	
Visual disorientation	
Topographical and spatial-memory deficits	
Lesions in monkeys	
Anatomical and Functional Organization	
Cytoarchitectural subdivisions	
Functional subdivisions	
Corticocortical connections	
Anatomical subdivisions defined by corticocortical connections	
Visual pathways into inferior parietal lobule (IPL)	
Callosal connections	
Thalamocortical connections—pulvinar	
Possible role of pulvinar in attention	
Medial pulvinar disks as one possible anatomical substrate for an attention mechanism	
Corticopontine projections	
Physiology	
Response properties of IPL neurons	
Fixation—eye-position activity	
Smooth-pursuit (tracking) activity	
Saccadic activity	
Somatosensory and reach activity	
Visual sensitivity	
Angle-of-gaze effects on light sensitivity	
Visual motion selectivity	
Attentional effects	
Speculations Regarding Role of IPL in Behavior	
Command hypothesis	
Attention hypothesis	
Visuomotor integration hypothesis	
Conclusion	

THE INFERIOR PARIETAL LOBULE (IPL) is located in the posterior aspect of the parietal lobe adjacent to the occipital lobe. It receives inputs from visual and somatosensory cortices and as a result has historically been considered an area important for the integration of these two modalities. This area is involved in higher cortical functions. Lesions here do not produce deficits in more primary aspects of vision (such as blindness)

or in somatosensation (such as loss of tactile sensitivity); they produce deficits in more complex cortical functions including spatial perception and visuomotor integration. Recordings from neurons in this area demonstrate more complex response properties than those found in lower-order sensory areas and larger receptive fields, indicating a greater degree of integration of visual information. It differs from lower-order sensory areas in that it has strong connections with diverse cortical structures such as limbic cortical regions believed to be important for emotions and drives, ventral temporal lobe areas thought to play an important role in memory, and prefrontal cortical areas that may be involved in motor planning.

Despite the complexity of the functions and connections of the IPL, much progress has been made recently in elucidating its role in cortical functioning. In particular, visual and oculomotor aspects of the IPL have lent themselves to careful experimental scrutiny; they are the subject of this chapter. Visual stimuli can be more precisely controlled than can somatosensory stimuli, and eye movements can be recorded simply and accurately, having many fewer degrees of freedom of movement than do limbs. A great deal is now known about the anatomy and, increasingly, the physiology of visual cortex. The direct and multiple connections between the IPL and extrastriate visual cortex provide avenues for elucidating the chain of processing events that result in the visual properties recorded in the IPL.

Progress has been more difficult in gaining an understanding of the somatosensory functions of this area and the possible role the IPL may play in the integration of somatosensory and visual information. It is becoming clear that an important integration of incoming visual signals and oculomotor signals occurs in the IPL and possibly plays a critical role in perception of and motor functioning within external space.

Recent experiments in subhuman primates have disclosed the presence of several visual cortical fields outside the primary (striate) visual cortex (for reviews see refs. 4, 208, 209). Many of these extrastriate fields, like striate cortex, contain a retinotopic representa-

tion of the contralateral visual field, systematically mapping corresponding points from the nasal and temporal retinas. Other extrastriate fields do not appear to be retinotopically organized but are nevertheless visual in function. Relatively few of these areas are polysensory; most appear to possess a predominantly visual function. It is estimated that there are ~20 visual cortical areas in the macaque monkey (209); even this large number is likely to increase as new areas are discovered and existing ones subdivided.

Single-unit recordings in these areas have identified different sets of functional properties, indicating that each area has a unique role in the processing of visual information. The clearest examples of specialization are found in the middle temporal (MT) area, which is involved in the processing of visual motion (2, 3, 54, 111, 126, 131, 211, 225), and in area V4, which may play an important role in color perception (224–226).

Many parallel corticocortical pathways emanate from striate cortex to extrastriate regions, and a great deal of cross talk interconnects these corticocortical streams (110, 209). A simplifying general observation, however, is that two major visual pathways with very different functions take their origins from primary visual cortex (area V1). One pathway passes dorsally in extrastriate cortex surrounding area V1 to end in the posterior parietal cortex; the other passes ventrally in cortex to end in the inferotemporal cortex (92, 207). Recording and lesion experiments indicate that the dorsal pathway is involved in processing spatial functions including the analysis of motion, selective attention, and visuomotor integration (38, 105, 122–124, 162, 209), whereas the ventral pathway concerns itself primarily with color, form, and pattern vision (51, 67, 145, 209). There are, then, two largely segregated cortical visual systems: one includes the IPL and is concerned with “where” objects are in the visual environment; the other includes the inferotemporal cortex and is concerned with “what” objects are (207). This chapter discusses primarily the “where” system and particularly its highest expression within the visual cortical areas of the IPL.

LESION STUDIES

Lesions in Humans

Lesions to the human IPL produce a number of debilitating and complex symptoms in the visual domain, including deficits in visual attention and impairment of visuospatial perception and orientation. The deficits include neglect, constructional apraxia, defects in visual localization, visual disorientation, disturbances in topographical relationships, and loss of spatial memory. [Critchley (45) gives a detailed review of the clinical literature. For a treatment of how lesion size and location influence the cluster of symptoms presented by these patients, see ref. 75.]

In humans the laterality (i.e., left hemisphere vs. right hemisphere) of the parietal lobe lesion importantly influences the severity and nature of the expression of symptoms. Right hemisphere lesions in right-handed individuals result in the most severe effects (45, 113, 151). Deficits in right-handers with left hemisphere lesions are often more difficult to assess because of an accompanying aphasia, but in many instances they appear qualitatively similar to, although less severe than, those observed to accompany right-sided lesions (46, 142). Unilateral left-sided lesions usually produce disturbances only in the contralateral space, although right-sided lesions can produce either contralateral or bilateral (global) effects.

ATTENTIONAL DEFICITS. Patients with posterior parietal injury often fail to attend to (“neglect”) the hemispace contralateral to the lesion. They may show total indifference to visual stimuli in the affected contralateral space that invoke considerable reaction when presented in the noninvolved visual space (77). Although capable of detecting a visual stimulus confined to the involved space, they often are blind to that area if a second stimulus is presented simultaneously in the opposite, unaffected hemifield [“extinction” (45)]. This neglect often extends to the contralateral body half; patients exhibit a lack of spontaneity and difficulty in dressing or a lack of grooming of the affected side. In severe cases, patients may deny that the affected body half belongs to them, or they may perceive body-image distortions such as supernumerary limbs (32, 45, 46, 49, 73, 74). Neglect syndromes in more minor forms also resulted from lesions to other areas of the brain that are strongly connected to the posterior parietal cortex, including the prefrontal cortex, cingulate cortex, and pulvinar.

CONSTRUCTIONAL APRAXIA. Constructional apraxia refers to difficulties in representing spatial relations in modeling and drawing (27, 73, 74, 113, 142, 151). Constructional deficits include abnormal representations of depth and perspective, misjudgments of size, and a “piecemeal” approach in which the subject proceeds from point to point in a drawing, failing to grasp the overall spatial framework. Figure 1 shows an example of constructional apraxia. Using blocks, a patient attempted to reproduce the structure on the *left*, with the rather poor results shown on the *right*. Figure 2 shows an example of a combination of attentional and constructional deficits. The patient was an artist who suffered a stroke affecting the right hemisphere. He was asked to paint self-portraits at different stages of recovery from a parietal lesion. Neglect can be seen, particularly in the earliest painting (*upper left*), in which the patient ignored completely the contralateral half of his face. Although he later improved, some of the spatial relations remained distorted.

VISUAL MISLOCALIZATION. Patients with parietal lesions often make errors in visual localization, as in-

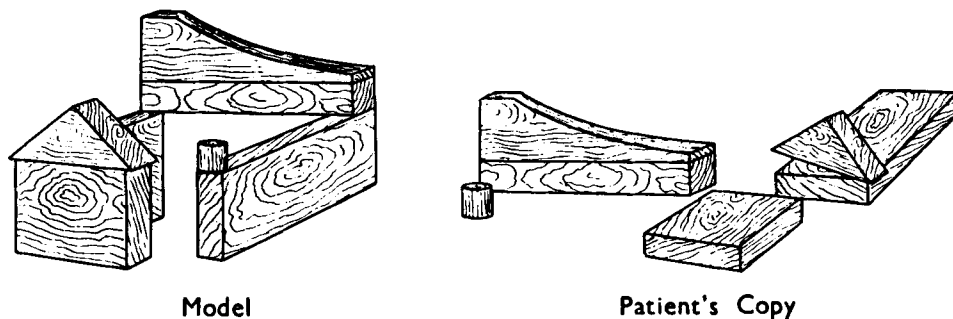

FIG. 1. Example of constructional deficit. Patient with left frontoparietal metastatic tumor was asked to copy block construction (*left*). Patient's copy (*right*) shows poor performance. [From Critchley (45).]

indicated by mistakes in reaching or pointing to visual targets (142, 155). Mislocalizations are usually restricted to one spatial hemifield regardless of which limb is used for pointing. These visuospatial deficits are not due to motor-reaching impairment (155). They often occur in the absence of defects of more primary visual functions and do not occur with lesions to the striate ("primary") visual cortex. Although the findings are controversial, some investigators report that patients with striate lesions can accurately localize visual targets by pointing, despite the fact that they are not consciously perceived ("blind pointing") (16, 144, 153, 215).

VISUAL DISORIENTATION. Patients with visual disorientation report that the environment appears "jumbled" so that they are unable to perceive the location of objects in space (77). This deficit can occur despite the ability to recognize the object and without accompanying visual-field defects (32, 45, 185). Affected persons estimate distances poorly (77, 142) and misjudge the relative sizes and lengths of objects (77). Often the visual disorientation includes an inability to distribute visual attention in space. In such instances patients cannot judge the relative positions of two objects and may even be unable to notice two objects simultaneously (57, 77). They typically report, "When I look at one thing, the rest vanish" (90). They lose the capacity to attend to backgrounds (185), to apply uniform frames of reference (142), or to appreciate a figure as a spatially organized unit. Attention to any one part of a figure destroys the effect of the whole (142).

Investigators have considered whether the parietal lobe syndrome is primarily a defect of visual attention or of visual space perception. The spatial deficits reported here could result from restricted visual attention, i.e., the inability to attend simultaneously to two or more objects in visual space. Bisiach et al. (30) have shown that a spatial deficit can exist even when attention is directed only to a single locus. Their patients with right parietal lesions looked at projected images that passed horizontally behind a viewing slit. Attention was centered on the slit, and using temporal cues

they attempted to reconstruct from mental images the spatial organization of the viewed objects. They neglected the parts of the image contralateral to their lesions. For instance, if a coffee cup was passed behind the slit, the handle was unobserved if on the left but was observed if on the right. This result indicates the presence of spatial deficits that exist independently of the distribution of visual attention.

TOPOGRAPHICAL AND SPATIAL-MEMORY DEFICITS. Patients with posterior parietal lesions commonly have an impairment of route-finding ability (32, 74, 77, 185, 197). Although spatioperceptual defects undoubtedly contribute to this deficit, topographical memory also appears to play an important role. Topographical memory loss was first described as one component of the Charcot-Wilbrand syndrome. Charcot's patient could no longer recognize landmarks in a town previously well known to him (53). Wilbrand's patient could usually not recall visual images of a topological or geographical nature, and those few images the patient could generate were profoundly spatially distorted (216). For instance, she believed that the street lay immediately outside her parlor, whereas her bedroom actually intervened, and believed that articles of her furniture were in the street rather than in her home. Although these particular patients had a wide variety of memory defects, reports of cases with deficits restricted to spatiotopographical memory have been described subsequently (see review in ref. 47).

Certain aspects of the neglect resulting from parietal lesions may be derived from spatial-memory deficits. Saper and Plum (173) have proposed that some aspects of neglect are the result of a loss of awareness of, for instance, the contralateral body half. They propose that this loss of awareness includes not only the loss of abstract perception but also the loss of internal spatial representations or memories against which this altered perception can be compared. This proposed memory loss would help to explain why these patients are not generally aware of their deficits.

A most ingenious experiment designed to elucidate the relationship of neglect to internal topographical memory was performed by Bisiach and Luzzatti (29).



FIG. 2. Self-portraits of stroke patient (German artist Anton Raderscheidt) with damage to right parietal cortex. Portraits were drawn 2 mo (*upper left*), 3.5 mo (*upper right*), 6 mo (*lower left*), and 9 mo (*lower right*) postlesion. Earlier portraits show side of face contralateral to lesion severely "neglected." [From Jung (84).]

They asked parietal patients with contralateral neglect to describe from memory landmarks bordering the Piazza del Duomo in Milan. First the patients were asked to imagine that they were standing at one end of the square facing the cathedral (Fig. 3, position A). From this perspective they remembered only those landmarks on the side of the square ipsilateral to the lesion (black circles). Next they were asked to imagine that they were at the other end of the square standing on the cathedral steps (position B). In this case they remembered only establishments located on the side of the square opposite those remembered from per-

spective A. Thus the lesions consistently interfered with the contralateral half of topographical memories as referenced to the body of the observer. These results suggest two possible interpretations: spatial memory may be referenced to the body with each half of the hemifield stored in the contralateral hemisphere and lost subsequent to the lesion, or there may not be a loss of spatial memory itself but a deficit in accessing or imaging all of it.

Although these examples pertain to spatial memories formed before the lesion, patients suffering parietal lobe damage also have difficulty forming new spa-

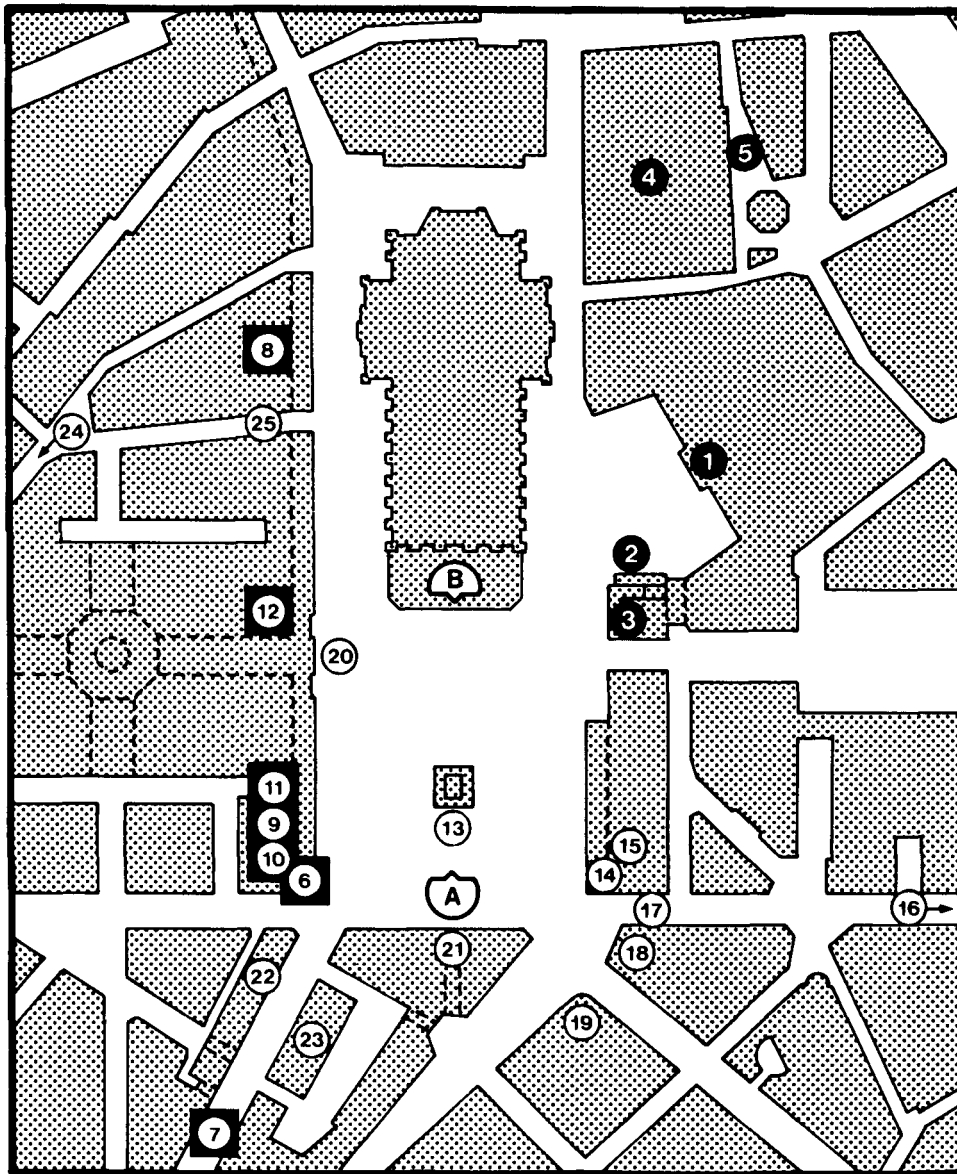

FIG. 3. Example of topographical memory deficit restricted to contralateral hemispace. Figure is map of Piazza del Duomo in Milan with various landmarks numbered. Right hemisphere stroke patient attempted to recall from two perspectives landmarks bordering square. *Numbered dark circles*, landmarks recalled from perspective A; *numbered dark squares*, landmarks recalled from perspective B. [Adapted from Bisiach and Luzzatti (29).]

tial memories. De Renzi et al. (48, 50) found that it took such patients considerably longer than normal to learn a path through a maze or to tap out a sequence on blocks. Because posterior parietal lesions both interfere with old spatial memories and create difficulty in the formation of new ones, it is likely that this area either stores spatial memories or represents a critical brain structure for their recall. This dual amnesia distinguishes the parietal lobe from the hippocampus, a more classic memory structure, in which lesions disrupt the ability to form new memories and the ability to maintain memories formed just prior to the lesion. The loss of both old and new memories with parietal lobe lesions is consistent with Mishkin's proposal that memories are stored in the same association cortical areas in which the perceptions are processed through the consolidating action of the hippocampus (119). In monkeys the IPL is directly connected to several areas in the temporal lobe associated with the hippocampal formation (183, 184).

Lesions in Monkeys

Posterior parietal lesions in monkeys produce many of the visuospatial defects found in humans, including neglect of the contralateral visual field, disuse and lack of grooming of the contralateral body half, and visual extinction. The most dramatic and consequently most studied deficit seen in these animals is their reluctance to use the contralateral limb in visually guided reaching, although they employ the limb appropriately in other tasks such as locomotion and climbing. When the contralateral limb is used in reaching, it is inaccurate in both hemifields (56, 58, 64, 72, 94, 120, 156). Although the reaching errors subside in a matter of weeks, often a permanent difficulty in coordinating fine digital movements under visual guidance remains (64). The reaching deficit is restricted to the limb contralateral to the lesion for motor operations in either hemifield. In this respect, the deficit appears to be somewhat different from that seen in humans with parietal lobe damage in whom accuracy is affected only for the spatial hemifield contralateral to the cortical lesion regardless of which limb is used. Stein (193), however, has demonstrated a reversible deficit in hand-eye tracking in monkeys that was confined to the contralateral visual field when area 7 was experimentally cooled. A general clumsiness of the contralateral arm was exhibited if area 5 was also cooled. Many experimenters studying lesions in this area have removed large extents of cortex that often include area 5.

Lynch and McLaren (102, 104) described oculomotor deficits in monkeys with parietal lesions, including a reduction in the mean velocity of the slow phase of optokinetic nystagmus, longer latencies for saccadic eye movements, and longer latencies for the initiation of smooth-pursuit eye movements.

Bilateral ablations of the posterior parietal cortex

produce severe visuospatial deficits in monkeys. Affected animals cannot judge the spatial relationship between two objects; e.g., they cannot determine which of two food wells is closer to a landmark, the closer food well being baited (37, 114, 152, 201). They also have difficulty in route following (149) and in finding their way back to their cages after being released.

ANATOMICAL AND FUNCTIONAL ORGANIZATION

Older associationalist views of the cortex held that the IPL was a polysensory area integrating vision and somatic sensation. It is now known that the caudal half of the IPL is likely to be largely visual and visuomotor in function and lies at the pinnacle of the dorsal cortical pathway, the "where" system involved in processing spatial functions. There is now sufficient anatomical and physiological evidence to indicate that the caudal visual region of the IPL contains several distinct cortical areas. The more rostral aspect of the IPL appears to be more concerned with somatosensory and somatomotor processes.

Cytoarchitectural Subdivisions

The IPL is located in the most posterior aspect of the parietal lobe. Brodmann (35) subdivided the monkey parietal lobe into several cortical areas based on cytoarchitectural distinctions. He divided the anterior aspect of the lobe into areas 3, 1, and 2 (anterior to posterior). These areas are collectively referred to as primary somatosensory cortex (SI), although recent studies have shown each of these areas to represent functionally and anatomically distinct cortical fields consistent with Brodmann's cytoarchitectural parcelations (85). The posterior parietal cortex contains the superior parietal lobule (SPL) and the IPL. Brodmann designated the SPL area 5 and the IPL area 7 (Fig. 4A). Area 5 contains exclusively somatosensory association cortex. Area 7 was later further subdivided cytoarchitecturally into two areas: a caudomedial area designated 7a by Vogt and Vogt (212) or PG by von Bonin and Bailey (213) and a more laterorostral area 7b or PF (Fig. 4B). The IPL includes not only the cortex on the gyral surface but also the cortex of the lateral bank of the intraparietal sulcus (IPS) and the cortex of the anterior bank of the caudal third of the superior temporal sulcus (STS). It also encompasses a small section of cortex on the medial wall of the cerebral hemisphere that Brodmann also labeled area 7 but that von Bonin and Bailey considered an extension of cortex of the SPL (their area PE). Pandya and Seltzer (138) have named this area PGM because they found this area to be a cytoarchitecturally separate cortical region from either area 7 or PE (see Fig. 5).

The exact homologies between areas of the posterior parietal cortex in monkeys and humans are unclear. Brodmann believed that human SPL is cytoarchitec-

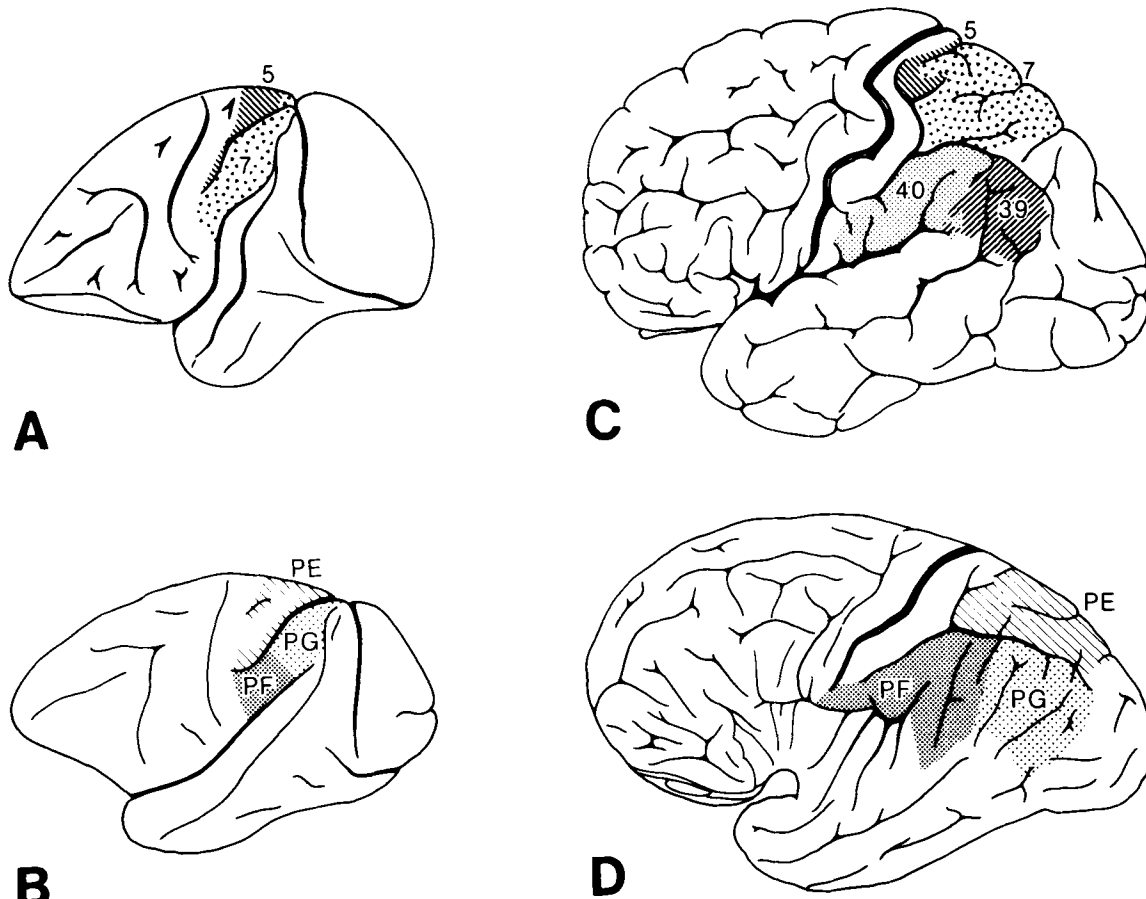

FIG. 4. Lateral views of monkey and human cerebral hemispheres showing different cytoarchitectural parcellation schemata of posterior parietal cortex. A: Brodmann's subdivisions of monkey cortex (*Cercopithecus*) (35). B: von Bonin and Bailey's classification of monkey cortex (*Macaca mulatta*) (213). C: Brodmann's parcellation of human cortex (36). D: von Economo's parcellation of human posterior parietal cortex (214). [From Andersen (6).]

turally the same as monkey IPL (Fig. 4A, C). Thus there would be no homologous area in the monkey for Brodmann's areas 39 and 40 that comprise the human IPL (Fig. 4C). However, von Bonin and Bailey criticized Brodmann's work in the monkey and claimed that their areas PG and PF were homologous to von Economo's PG and PF that include the IPL in humans (Fig. 4B, D). The fact that lesions of the IPL in monkeys and humans produce similar visual disorders, whereas SPL lesions in humans generally result in somatosensory disorders, argues for the view of von Bonin and Bailey.

Functional Subdivisions

Hyvärinen and Shelepin (79, 81) made systematic maps of the functional organization of the IPL and found that the caudal aspect possesses predominantly visual and visuomotor functions, whereas the more lateral areas represent somatosensory and visual activity. In these experiments a rather qualitative approach was used for appraising visual and visuomotor

activity. Andersen et al. (10) confirmed this organization using paradigms that brought the visual stimuli and oculomotor behaviors under experimental control. Robinson and Burton (159, 160) made extensive maps of area 7b in behaving monkeys and found that 80% of the neurons responded to somatosensory stimuli. Although they found the somatic receptive fields to be very large (in some cases including the entire body), they did find a crude topographical arrangement with the head represented medially on the convexity of the IPL near the IPS and the lower trunk and legs located more laterally on the upper bank of the lateral sulcus caudal to SII. About 10% of area 7b cells were reported to be visual, and another 10% were both visual and somatosensory, confirming the reports of Hyvärinen and Shelepin (81) of some somatosensory-visual convergence for single neurons in area 7b.

There are probably additional functional subdivisions within the caudally located visual/visuomotor aspect of the IPL. Additional mapping experiments with rigorous controls are needed to establish more precisely the degrees of overlap and segregation that

exist for the various cell classes that have been identified in this region. However, anatomical evidence reviewed in ANATOMICAL SUBDIVISION DEFINED BY CORTICOCORTICAL CONNECTIONS, this page, indicates that area PG contains at least three cortical areas: the lateral intraparietal (LIP) area in the caudal half of the lateral bank of the IPS, the medial superior temporal (MST) area located on the anterior bank of the caudal aspect of the STS, and area 7a, located on the gyral surface. Note that this area 7a is considerably smaller than the area 7a that was defined by Vogt and Vogt (212) on cytoarchitectural criteria alone. Area LIP appears to play a role in saccadic eye movements. Shibutani et al. (186) reported lower thresholds for evoking saccades with electrical stimulation to this area. Andersen et al. (10) reported saccade-related neurons in area LIP, although they also found fewer but substantial numbers in area 7a. This sulcal region provides a much stronger projection than the gyral surface of the IPL to the frontal eye fields and superior colliculus, structures involved in the generation of saccades. Sakata et al. (171) and Wurtz and Newsome (219) found cells responding during smooth pursuit primarily in the anterior bank of the STS. At least a portion of these cells were located within area MST. Many cells in this area are sensitive to relative motion, responding to size change and rotation (167, 172). Eye-position neurons, which convey information regarding the position of the eyes in the orbits, are found in approximately equal numbers in areas 7a and LIP (10).

These observations indicate that the IPL can be subdivided into a largely somatosensory area more or less coextensive with area PF and a visual area within area PG. This visual area appears to contain additional subdivisions based on different visual and visuo-motor properties recorded from these regions.

Corticocortical Connections

Initial anatomical tracing experiments established that the IPL was connected to many regions of the brain involved in the highest aspects of cortical functioning (10, 12, 15, 42, 52, 82, 83, 91, 95, 116, 117, 128, 136, 137, 139, 141, 150, 174, 175, 180-184, 192). It was found to connect reciprocally to the dorsolateral prefrontal cortex, a premotor area thought to be involved in the most complex aspects of motor planning (see refs. 61, 62 for reviews on prefrontal cortex function). The IPL was also found to possess extensive reciprocal connections with a considerable portion of STS cortex, an area that Jones and Powell (83) proposed to be the highest area of convergence of the three major sensory systems. Other projection zones in the temporal lobe are those associated with memory function, including the hippocampal formation (the cortex of the parahippocampal gyrus, the presubiculum, and the perirhinal cortex). Areas believed to be involved in emotions and drives, including the retrosplenial cortex

and the entire extent of the cingulate gyrus, and areas believed to be involved in higher aspects of somatosensation, including the insular cortex, SPL, and medial wall of the parietal lobe, were all reported to have reciprocal connections with the IPL. Many of these areas also interconnect reciprocally with one another so that the IPL appears to be a node in a large network of connections that includes some of the highest-order processing areas of the cerebral cortex. Clinical observations indicate that damage to many of these loci produce neglect, although the type of neglect differs qualitatively: parietal lesions lead to spatial neglect, cingulate lesions produce affective neglect, and prefrontal lesions result in motor neglect [reviewed by Mesulam (115)].

ANATOMICAL SUBDIVISIONS DEFINED BY CORTICOCORTICAL CONNECTIONS. In recent years, more detailed studies of IPL connections have revealed different sets of connections for different locations within the lobule. This segregation of connections suggests but does not in itself establish a multiplicity of cortical fields contained within the IPL because ideally, as Rose (166) pointed out, a cortical region should be defined by coexisting differences in function, cytoarchitecture, and connections. One functional distinction, the topographical representation of sensory epithelia, has little impact in defining subdivisions in the IPL, because its visual areas do not appear to be retinotopically organized and area 7b at best contains only a crude topography of the body (159, 160). It will be seen that many of the areas that can be recognized on the basis of connections also show a corresponding segregation of functional properties. Some cytoarchitectural and myeloarchitectural borders also exist for the connectionally defined parcellations.

Anatomically defined subdivisions of the IPL are described next. Reference to Figures 5 and 6 is helpful in locating these areas.

Lateral bank of IPS. The cortex of the lateral bank of the IPS probably contains more than one cortical field. Seltzer and Pandya (182), who originally named this entire area POa, noted that the caudal aspect of the sulcus receives input from extrastriate visual cortex in the prelunate gyrus, whereas the more rostral aspect of the sulcus receives inputs from area PF (area 7b). Area LIP, which comprises the caudal half of the lateral bank of the IPS, appears to play some role in saccadic eye movements. As mentioned previously, eye movements can be evoked here with lower currents of electrical stimulation than are required for other locations in the IPL (186). This area also tends to have more saccade-related activity than is found in other IPL locations (10). Consistent with these observations are the anatomical findings that this area projects to the superior colliculus and has reciprocal connections with the frontal eye fields, the latter two structures being essential for the generation of saccadic eye movements (7, 11, 15, 103). Area 7a has only weak

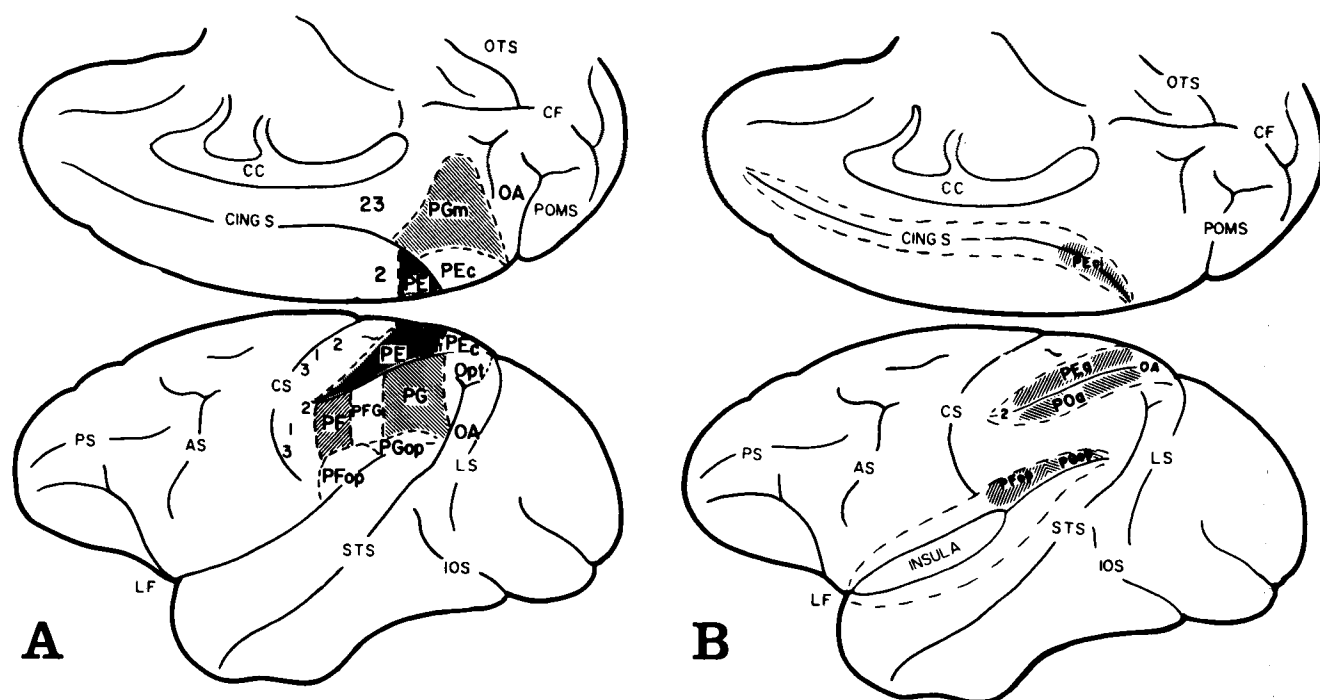

FIG. 5. Parcellation of monkey posterior parietal cortex (*Macaca mulatta*) based on cytoarchitecture and patterns of corticocortical connections. *Upper drawings*, medial surface; *lower drawings*, lateral surface. *A*: subdivisions of cortical hemisphere. *B*: lateral, intraparietal, and cingulate sulci have been opened up to show areas inside. AS, arcuate sulcus; CC, corpus callosum; CF, calcarine fissure; CING S, cingulate sulcus; CS, central sulcus; IOS, inferior occipital sulcus; LF, lateral fissure; LS, lunate sulcus; OTS, occipitotemporal sulcus; POMS, parieto-occipital medial sulcus; PS, principal sulcus; STS, superior temporal sulcus. [From Pandya and Seltzer (138).]

connections, and area 7b no connections, with the frontal eye fields and superior colliculus. Area LIP also contains neurons with visual- and eye-position-related activity (10, 187; R. A. Andersen, R. M. Siegel, G. K. Essick, and C. Asanuma, unpublished observations). This area receives inputs from several extrastriate visuocortical fields.

The ventral intraparietal (VIP) area lies in the fundus of the sulcus joining the ventral border of area LIP and was defined by its connections with area MT, a cortical field on the posterior bank of the STS important for visual motion processing (111). The ventral aspect of area LIP contains a subregion that stains strongly for myelin and also receives inputs from area MT (204). Both this area and more dorsal aspects of area LIP project to area 7a.

Anterior bank of STS. Cells recorded from the anterior bank of the STS in the general area of the MST respond to smooth-pursuit eye movements and to visual motion including complex relative motions such as expansion, compression, and rotation (167, 171, 172, 196, 219). Area MST receives direct projections from several extrastriate visual areas, including area MT, and projects to areas 7a and LIP in the IPL (43, 110, 183, 187).

Area 7a. Area 7a, as defined here on the basis of connectional and functional criteria, is actually

smaller than the area 7a earlier described by Vogt and Vogt (212) and defined on the basis of cytoarchitecture; it includes areas PG and Opt of Pandya and Seltzer (138). Area 7a is another visual and visuomotor area of the IPL. A majority of the cells studied in this area have visual receptive fields (8a, 79, 122). Many of these cells also carry eye-position signals and some cells have saccade-related activity (8a). The visual excitability of many neurons found in this area changes as a function of the angle of gaze; similar neurons are occasionally found in area LIP (8).

Area 7a possesses more extensive connections with high-order areas in the frontal and temporal lobes and cingulate gyrus than do other cortical fields in the IPL. It projects strongly to the prefrontal cortex in and around the principal sulcus (area 46 of Walker), but unlike area LIP, it connects only weakly to the frontal eye fields (10, 15, 187). It possesses strong interconnections with limbic cortex projecting to the entire cingulate gyrus, the most dense connections being to area LC in the posterior half of the gyrus (139). Area 7b is connected primarily, if not exclusively, to area LA in the anterior cingulate gyrus (139; R. A. Andersen, R. M. Siegel, G. M. Essick, and C. Asanuma, unpublished observations).

Of all the IPL areas, area 7a demonstrates the most extensive connections with the cortex of the STS (181,

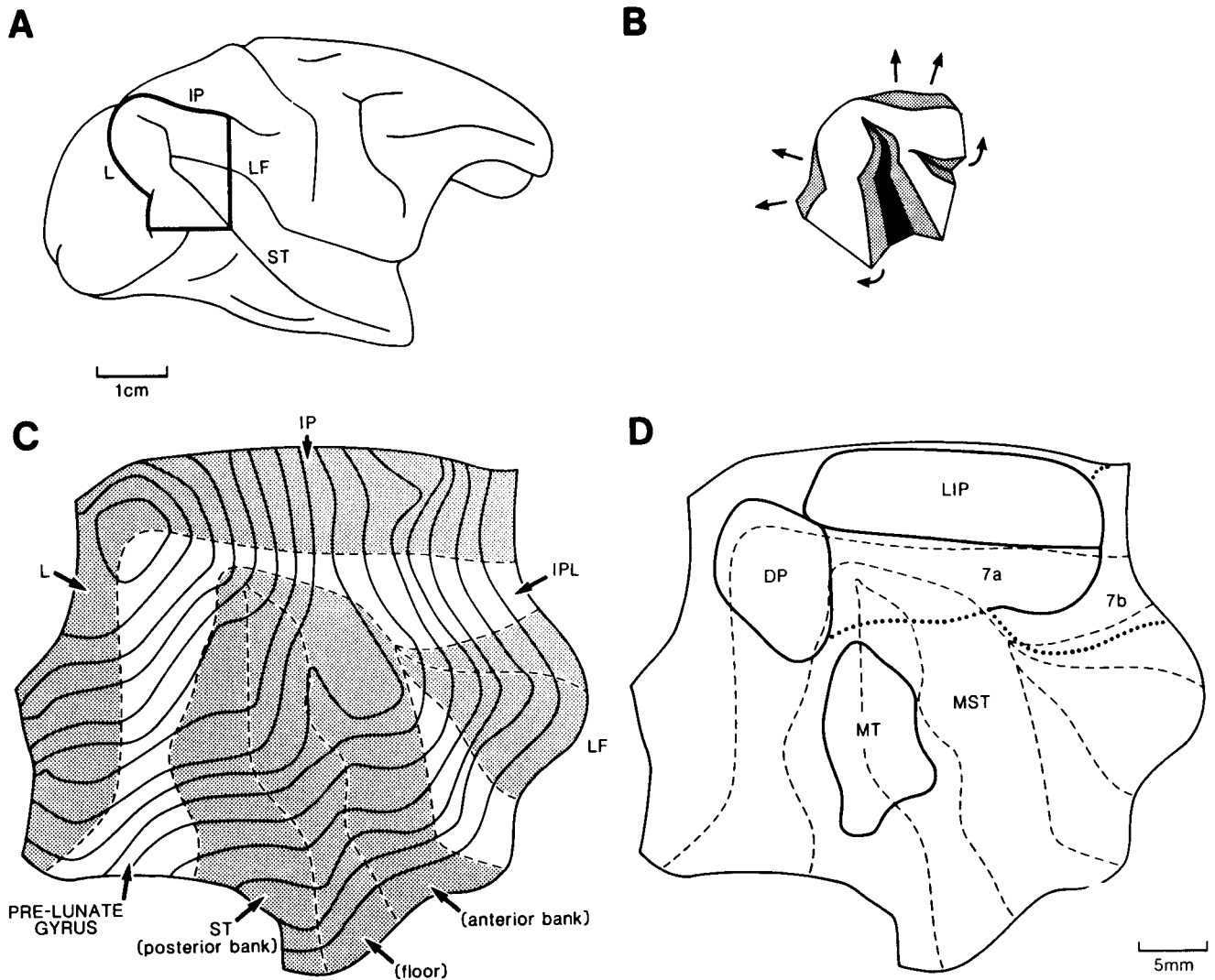

FIG. 6. Parcellation of inferior parietal lobule and adjoining dorsal aspect of prelunate gyrus based on physiological, connective, myeloarchitectural, and cytoarchitectural criteria. Cortical areas are represented on flattened reconstructions of cortex (211). *A*: lateral view of monkey hemisphere. *Darker lines* outline flattened area. *B*: same cortex isolated from rest of brain. *Stippled areas*, cortex buried in sulci; *blackened area*, floor of superior temporal sulcus (ST); *arrows*, movement of local cortical regions resulting from mechanical flattening. *C*: completely flattened representation of same area. *Stippled areas*, cortical regions buried in sulci; *contourlike lines*, tracings of layer IV taken from frontal sections through this area. *D*: locations of several cortical areas. *Dotted lines*, borders of cortical fields not precisely determinable. DP, dorsal prelunate area; IP, intraparietal sulcus; IPL, inferior parietal lobule; L, lunate sulcus; LF, lateral fissure; LIP, lateral intraparietal area; MST, medial superior temporal area; MT, middle temporal area.

183). It connects with the anterior bank of the caudal aspect of the STS including area MST (182, 183; R. A. Andersen, R. M. Siegel, G. K. Essick, and C. Asanuma, unpublished observations). At middle levels of the STS, area 7a is connected primarily with the anterior bank, and this projection appears at least partially to overlap the superior temporal polysensory (STP) area where both visual and auditory responses have been reported from single neurons (37a). A third connection is between area 7a and the fundus and posterior and anterior banks of the STS in their most anterior extent. This projection zone may include a

portion of the inferotemporal cortex in the STS. A large number of pattern-selective cells responding to faces have been reported in this sulcal region, which in turn is connected with the inferotemporal cortex on the convexity of the inferior temporal gyrus (51, 68, 145, 181). This projection is a possible link for interconnecting the "where" system of the IPL with the "what" system of the inferotemporal cortex.

As discussed in *TOPOGRAPHICAL AND SPATIAL-MEMORY DEFICITS*, p. 485, lesions of human IPL produce spatial-memory deficits. Area 7a connects with areas in the temporal lobe that may play a pivotal role

in memory, including two or three cortical fields in the parahippocampal gyrus and occipitotemporal sulcus, the presubiculum of the hippocampal formation, and perirhinal cortex in both banks of the rhinal fissure (183, 184; R. A. Andersen, R. M. Siegel, G. K. Essick, and C. Asanuma, unpublished observations). These temporal lobe connections may be important pathways for area 7a operations subserving spatial memory.

Area 7b. Neurons in area 7b generally respond to somatosensory stimuli, and it is not surprising that this area connects predominantly to other somatosensory cortical areas including the insular cortex (116, 128, 150; R. A. Andersen, R. M. Siegel, G. K. Essick, and C. Asanuma, unpublished observations), area SII (138, 192), and area 5 (39, 60; R. A. Andersen, R. M. Siegel, G. K. Essick, and C. Asanuma, unpublished observations). The projection of area 7b to premotor areas in the frontal lobe terminates more ventrally than the 7a and LIP projections in area 45 of Walker [or ventral areas 46 and 8 of Petrides and Pandya (150)] and the ventral area 6 (150; R. A. Andersen, R. M. Siegel, G. K. Essick, and C. Asanuma, unpublished observations). Area 7b projects only to a single locus in the STS that appears to border area MST near the lip of the anterior bank (area TPO) (183; R. A. Andersen, R. M. Siegel, G. K. Essick, and C. Asanuma, unpublished observations). Pandya and Seltzer (138) divided area 7b into areas PGF, PF, and PGop.

Area PGm. Area PGm is located on the medial wall of the parietal lobe bordering cingulate cortex dorsally and caudally (138). Recording experiments have not been done in this area, but judging from its connections it is likely to subserve predominantly somatosensory functions. The region reciprocally connects with caudal area 24 of the cingulate (139, 150), projects to rostral area 6 in the frontal lobe (150), and projects to area TPO above area MST in the caudal third of the anterior bank of the STS (183). It reciprocally connects with parts of area 5 and with area PG, and it appears to represent a major pathway for somatosensory inputs to the IPL (138).

Dorsal prelunate area. The dorsal prelunate (DP) area borders areas V4 dorsally and 7a posteriorly. Although technically not a part of the IPL (being located on the dorsalmost aspect of the prelunate gyrus) it is strongly connected to the caudal aspect of the IPL. Area DP neurons respond to visual stimuli (10, 187). It receives inputs from other extrastriate cortical areas and projects to areas LIP, MST, and, more weakly, 7a in the IPL (R. A. Andersen, R. M. Siegel, G. K. Essick, and C. Asanuma, unpublished observations).

VISUAL PATHWAYS INTO IPL. Visual inputs into the IPL come predominantly from V1 by way of extrastriate cortex. A possible second source is found in the pathway from the retinorecipient areas of the superior colliculus and pretectum through the pulvinar to the

IPL. Visual inputs from this pathway are probably of minor significance. The retinorecipient (superficial) layers of the superior colliculus project to the inferior pulvinar and ventral aspect of the lateral pulvinar (19, 26, 71, 199); these pulvinar areas do not project to the IPL (11, 220). Area 7a receives its pulvinar input from the medial pulvinar (11, 220). Only the deep, oculomotor layers (and not the superficial visual layers) project to the medial pulvinar, which does not receive descending corticothalamic projections from other visual cortices (19, 26, 71). Thus, with the exception of a minor projection from the pretectum (26), no obvious visual inputs enter the medial pulvinar that could be relayed to area 7a. Areas LIP and DP receive their principal thalamic inputs from the dorsal nonretinotopic aspect of the lateral pulvinar (11). Cells in this area are weakly driven by visual stimuli, and again, this region receives inputs only from the oculomotor part of the superior colliculus and from the pretectum (25, 26, 71).

The presumed flow of visual processing can be determined by the laminar distributions of the sources and terminations of corticocortical projections in visual cortex (110, 164). In the early parts of the visual pathway, feedforward projections originate from cell bodies located in the supragranular layers and end in terminals in layer IV and lower layer III (Fig. 7). Feedback projections originate in the supragranular and infragranular layers and end most densely in layers I and VI (Fig. 7). The hierarchical progression for visual processing can be traced from area V1 on

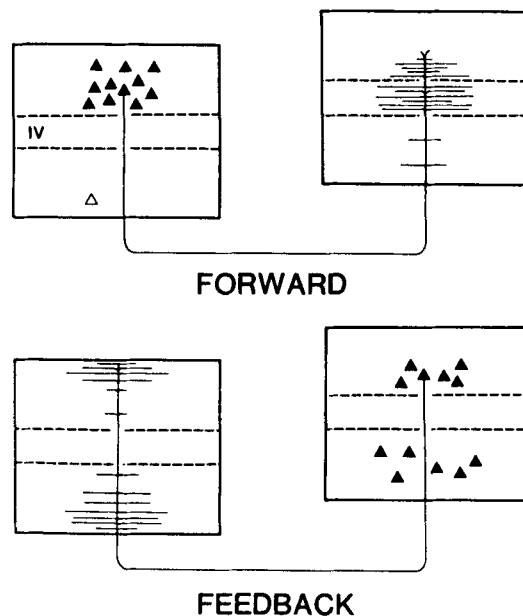

FIG. 7. Laminar distribution of sources and terminations of feedforward and feedback corticocortical pathways. Feedforward pathways originate predominantly from cell bodies in superficial layers and end as terminals mainly in layer IV. Feedback pathways originate from superficial and deep layers and terminate mainly outside layer IV. [From Maunsell and Van Essen (110).]

the bottom of the hierarchy to area 7a on the top by making one modification to this scheme for the projections into the IPL: feedforward projections originate in both superficial and deep cortical layers but still end predominantly in layer IV and lower layer III (12).

Figure 8A shows the routes of visual input into the IPL (dashed square) arranged in a hierarchical structure determined by the laminar distribution of the sources and terminals of the connections. Each line represents reciprocal corticocortical connections between fields. Multiple visual pathways project into the IPL, and area 7a is at the very top of this hierarchy. Figure 8B shows the shortest paths from area V1 to area 7a; each of these paths must pass through two of three extrastriate visual areas prior to arriving at area 7a. Of particular importance to motion processing is the pathway that begins in area V1 and passes through areas MT and MST to area 7a. This pathway and its role in motion processing are discussed in VISUAL MOTION SELECTIVITY, p. 504.

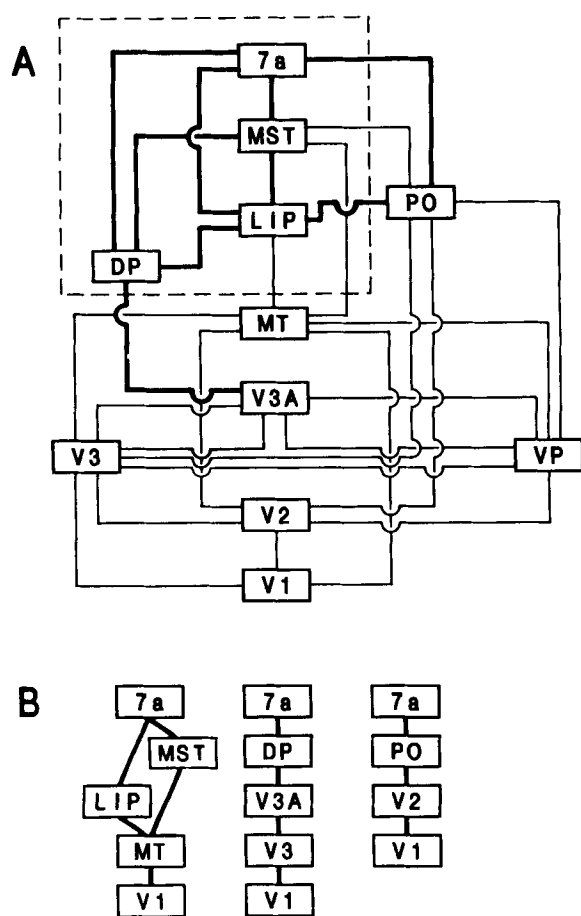

FIG. 8. A: hierarchy of visual pathways from area V1 to inferior parietal cortex determined by laminar patterns of sources and terminations of projections. Dashed box, cortical areas of inferior parietal lobule and dorsal aspect of prelunate gyrus. B: 3 of shortest pathways for visual-information travel from area V1 to area 7a.

CALLOSAL CONNECTIONS. The caudal aspect of the IPL connects to many of the same areas in the contralateral hemisphere to which it is connected in the ipsilateral hemisphere. These areas include the cingulate gyrus, STS, occipitotemporal sulcus, and the medial parietal cortex (74a). There are also extensive homotopic connections between the IPL of the two hemispheres (74a). Callosal connections between the IPL and the contralateral frontal lobe have not been found.

Double-label experiments have revealed that the arrays of IPL neurons projecting to the contralateral IPL are extensively intermixed in the cortex with those cells projecting ipsilaterally to the prefrontal cortex (7, 174, 175). However, very few of these cells were double labeled, indicating that the two projecting populations are largely separate (7, 174, 179).

Thalamocortical Connections—Pulvinar

All inputs to the cortex (with the exception of olfactory inputs and projections from the claustrum, amygdala, and small cell groups in the brain stem and the basal forebrain) must pass through the thalamus. For this reason the thalamus has been called the "gateway to the cortex," and knowledge of the structure and function of this nucleus is likely to be an important key to understanding the cerebral cortex.

Every part of the cortex that has been studied has been found to receive inputs from the thalamus. The cortex in turn exercises powerful control over the thalamus. All thalamocortical connections are reciprocal, with the cortex projecting back onto the same groups of cells that provide its input.

The pulvinar contributes the major thalamic input to the IPL and is the largest thalamic nucleus in the monkey. Not only does it connect with all of the visual cortex but also with many of the cortical regions involved in the highest aspects of cortical function. With the great expansion of cortex in humans has come a similar disproportionate enlargement of this particular thalamic nucleus. For these reasons, a complete understanding of the IPL requires some discussion of the pulvinar.

Four cytoarchitectural subdivisions of the pulvinar are recognized: the inferior, lateral, medial, and oral nuclei (135). The lateral pulvinar has been further subdivided on the basis of different connections and functional properties.

The pulvinar contains two topographical representations of the visual field. One is located in the inferior pulvinar and spills over into the immediately adjacent aspect of the lateral pulvinar; the second representation is located in the ventral half of the lateral pulvinar (17). These two areas receive ascending projections from the ipsilateral superficial (visual) layers of the superior colliculus (19, 26, 71, 199). They reciprocally connect with cortical areas V1, V2, and MT and possibly with other retinotopically organized extra-

striate visual regions in the macaque monkey (18, 24, 101a, 110, 132–134, 157, 189, 191, 200, 205, 206).

The oral pulvinar, medial pulvinar, and dorsal (non-retinotopic) aspect of the lateral pulvinar project to the IPL (11, 52, 87, 117, 220). These areas receive ascending inputs from the deep (oculomotor) layers of the superior colliculus and the pretectum (19, 26, 71). Different subdivisions of the IPL connect reciprocally with different pulvinar subdivisions: area 7b to the oral pulvinar, area 7a to the medial pulvinar, and areas LIP and DP to the lateral pulvinar (11, 220). Neurons in the oral pulvinar, like those in area 7b, respond to somatosensory stimuli (1). Neurons in the dorsal aspect of the lateral pulvinar are activated by light, have large bilateral receptive fields, and have saccade-related activity (20, 147, 148); the medial pulvinar has yet to be studied electrophysiologically.

POSSIBLE ROLE OF PULVINAR IN ATTENTION. Results from recording and lesion studies suggest that the pulvinar contributes to processes mediating attention. Lesions of the pulvinar consistently produce gaze defects in monkeys and humans (40, 134a, 202, 203, 228). Subjects tend to “grasp” objects with fixations, making fewer saccades and appearing to have difficulty disengaging the fixations. Unilateral pulvinar lesions in humans produce difficulty in scanning and visual search in the contralateral visual field (134a). This behavior has been attributed to defective visual-perceptual processing and not to defects in oculomotor performance because all other measurements of eye movements appear normal (203).

Chalupa et al. (40) found that the ability to learn pattern discriminations for tachistoscopically presented stimuli (10-ms presentations) was severely compromised by inferior but not lateral pulvinar lesions. Monkeys were required to distinguish an “N” from a “Z” (a 90° rotation of the “N”), a task easily learned prior to lesioning. Although some of the animals with inferior pulvinar lesions eventually were able to master the discrimination task, background distractions such as an annulus around the figure blocked their capacity to learn it. The results suggest the presence of attentional difficulties in discerning the object of the discrimination task.

Both monkeys and humans respond to a stimulus faster if they have been cued regarding the location in space at which the stimulus will appear (146, 154, 154a, 163). Injection of γ -aminobutyric acid (GABA) agonists (which increase inhibition) into the medial and lateral pulvinar increased the benefits of this cuing effect, whereas GABA antagonists eliminated the benefits of the cue (146, 163).

MEDIAL PULVINAR DISKS AS ONE POSSIBLE ANATOMICAL SUBSTRATE FOR AN ATTENTION MECHANISM. The medial pulvinar projection to area 7a arises from disklike arrays of neurons. The corticothalamic projection of area 7a ends in these same disks (11). The projection generally begins as two disks in the

anterior aspect of the nucleus, one of which divides in the posterior aspect of the nucleus to form a total of three disks (Fig. 9). These connections are topographically ordered within each disk, indicating that area 7a is represented at three different loci in the nucleus (11). Disklike arrays of neurons in the medial pulvinar are also found to project to the prefrontal cortex (11, 198). Double-label retrograde tracing experiments have shown that the cells from the prefrontal and 7a disks are intermingled and that the disks partially overlap. Only rarely, however, were double-labeled pulvinar cells found that sent axons to both area 7a and the prefrontal cortex (11). Projections from the temporal lobe to the medial pulvinar also end in a set of disks of similar orientation and size to the prefron-

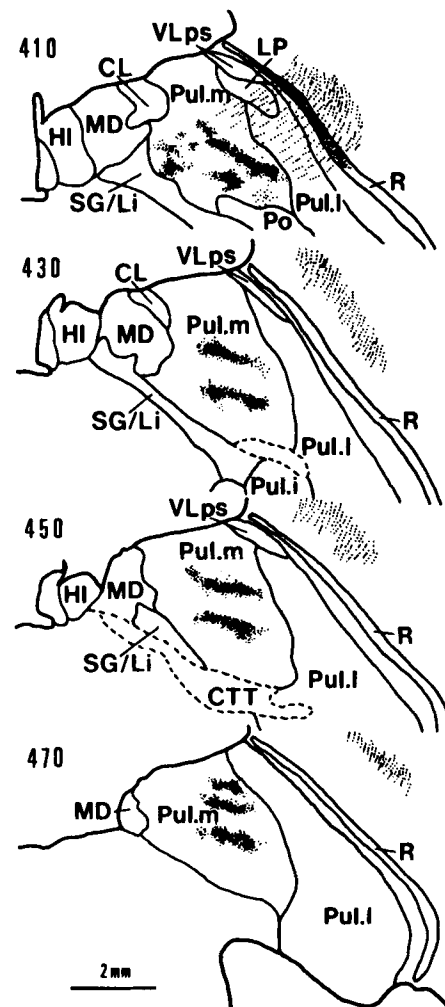

FIG. 9. Disklike distribution of labeled terminals in medial pulvinar after injection of tritiated amino acids in area 7a. Drawings of frontal sections through pulvinar are arranged with anterior sections above posterior sections. CL, central lateral nucleus; HI, lateral habenular nucleus; LP, lateroposterior nucleus; MD, mediadorsal nucleus; Po, posterior nucleus; Pul. i, inferior nucleus of pulvinar complex; Pul. l, lateral nucleus of pulvinar; Pul. m, medial nucleus of pulvinar; R, thalamic reticular nucleus; SG/Li, suprageniculate and limitans nuclei; VLps, ventral lateral nucleus pars postrema. [Adapted from Asanuma et al. (11).]

tal and 7a disks (188). It is possible that these findings of a multiple-disk structure, topographical representations within disks, and a partial overlapping of disks projecting to different areas constitute general rules for the organization of the thalamocortical-corticothalamic medial pulvinar projections.

The medial pulvinar connects with many of the same cortical areas as does area 7a, including the insular cortex, STS, prefrontal cortex, and cingulate cortex (11–13, 87, 129, 143, 189, 198, 200, 220); all of these cortical areas reciprocally connect with one another (15, 42, 52, 82, 83, 91, 95, 96, 116, 117, 128, 136, 137, 139, 140, 150, 175, 181, 183, 192; R. A. Andersen, R. M. Siegel, G. K. Essick, and C. Asanuma, unpublished observations). The medial pulvinar projection is most dense in layer III of the cortex; this layer is also the largest source of the corticocortical projections. One possibility is that the medial pulvinar plays a role in attention by regulating corticocortical transmission between these various diverse areas. The partially overlapping, topographical disk structure of the thalamocortical connections means that any small anatomical locus of the medial pulvinar connects with extensive areas of the cerebral cortex in a precise topographical fashion. These structural arrangements could provide an ideal switching station for controlling transmission between cortical fields within this network that is responsible for the brain's highest levels of functioning.

Corticopontine Projections

The IPL lies in the pathway that regulates the smooth-pursuit eye-movement system. Lesions to striate cortex produce smooth-pursuit deficits (66). Neurons sensitive to motion direction in area V1 project to area MT (127), which contains predominantly direction-selective neurons and appears to play an important role in motion processing (see ref. 209 for review). Newsome et al. (131) produced a deficit in pursuit initiation (in which monkeys consistently underestimated the velocity of moving targets) by placing lesions in the peripheral-visual-field representations of area MT. The deficit occurred only for stimuli presented at appropriate visual-field locations that corresponded to lesions of the retinotopic representations of area MT. The deficit was selective for moving stimuli because the animal could make accurate saccades to the retinal locus of the lesion. Lesions in the foveal representation of area MT produced a more motorlike deficit in which the animal showed deficits in maintaining pursuit only for tracking toward the side of the lesion (55a). Again the deficit was in motion processing because positional tracking of stabilized targets was not affected. As discussed in SMOOTH PURSUIT (TRACKING) ACTIVITY, p. 498, cells in area MST and perhaps in area 7a that receive projections directly or indirectly from area MT possess pursuit-related activity and probably play an important role in smooth-pursuit eye movements.

The dorsal cortical visual pathway (the "where" system) provides a majority of the corticopontine projections (34, 63, 65). Small lesions in the pons also disrupt the initiation and gain of smooth-pursuit eye movements (195). The target of the pontine projections, the cerebellum, also figures prominently in smooth-pursuit functions because lesions of the cerebellum disrupt tracking eye movements (223).

The IPL sends a substantial projection to the pontine nuclei. The corticopontine projections from different subregions of the IPL exhibit different patterns of termination (111a). Areas DP and LIP project primarily to the dorsal and dorsolateral pons. Area 7a projects to three areas of the lateral margin of the pons: the ventral, lateral, and dorsolateral nuclei; area 7b projects to these same lateral areas but also sends fibers to ventromedial portions of the ventral, peduncular, and paramedian pontine nuclei. No projections to the nucleus reticularis tegmentis pontis have been found. As expected, areas DP, LIP, and 7a project to pontine nuclei whose cells have visual and eye-movement-related responses (89, 130, 194), whereas area 7b projects to medial pontine nuclei that receive inputs from premotor and motor cortex (34).

PHYSIOLOGY

Response Properties of IPL Neurons

The earliest single-unit recording experiments in the IPL were made in awake, behaving monkeys by Mountcastle and co-workers (102a, 105, 106, 124) and Hyvärinen and colleagues (79a, 80, 97, 98). These investigators initially used descriptive examinations to gain a general understanding of what classes of stimuli and motor behaviors would activate these neurons. They delivered somatosensory stimuli by rotating joints, palpating muscles, and mechanically stimulating the skin. They presented visual stimuli with flashlights or hand-held objects and produced auditory stimuli by clapping hands, jiggling keys, and so on. Motor responses were elicited by having the animals look toward or reach for objects, usually food, held in front of them. Area 7 neurons were found to be activated by visual and somatosensory stimuli, by oculomotor behaviors including fixation and eye movements, and by the animal's reaching for objects and manipulating them. Mountcastle and co-workers then performed more quantitative studies of parietal neurons by designing controlled eye-movement and reaching tasks. Although the qualitative analyses represented a valuable first step in the exploration of a new cortical region, they recognized that controlled paradigms were essential for determining precisely which features were activating the neurons.

Figure 10 illustrates the quantitative recording techniques used in most of the studies described next. In a typical oculomotor task, the animal (with head fixed) fixates a point of light on a screen in front of it and maintains fixation by following any movement of the

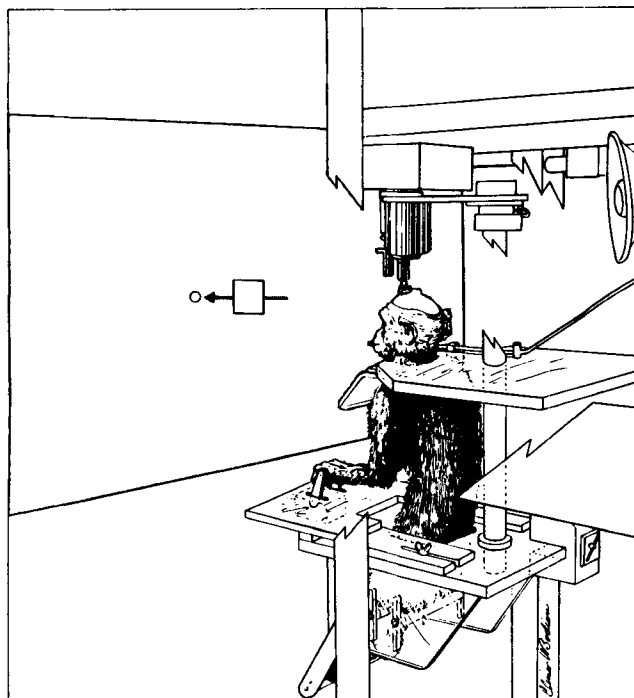

FIG. 10. Typical apparatus used for inferior parietal lobule recording experiments from awake behaving monkeys. [From Motter and Mountcastle (122).]

light. Often, as shown in Figure 10, the animal pulls back a lever when the fixation point appears and pushes forward the lever when the fixation point dims slightly. If it makes the appropriate eye movements and detects the dimming of the fixation target within a brief reaction-time window, it receives a drop of juice as reward. In another task used to map the visual receptive fields of neurons, the animal maintains fixation on a stationary target while a second test stimulus that it is trained to ignore flashes or moves in the visual field (Fig. 10). Trained animals perform 1,000–2,000 trials per daily recording session. Eye position and cell activity are recorded, and correlations between neural activity and eye movements or visual stimulation are analyzed by computer. In the reaching tasks the animals are trained to reach for and touch a panel to receive a reward. Recent findings with these techniques are outlined next.

FIXATION—EYE-POSITION ACTIVITY. Mountcastle et al. (124) described a class of neurons activated during fixation. These cells appeared not to respond to visuosensory stimuli such as lights flashed in the visual field but were activated by the motor act of fixating. The fixation cells were continuously active when the animal fixated an object of interest. They were also activated when the animal fixated a projected spot of light to detect its dimming; however, the “transference” of the fixation activity from the object itself to a light on the tangent screen often appeared to be incomplete. Later experiments by this group showed that most of the fixation cells had maximal activity

for animals fixating at specific angles of gaze with heads fixed (105). They defined the “gaze field” of these cells as the zone of space within which fixation evoked their activity. Saccadic eye movements suppressed fixation activity.

Subsequent investigations have confirmed the observation of Lynch et al. (103) that almost all fixation neurons have gaze fields (8a, 170). It therefore may be more appropriate to consider them “eye-position” neurons because they signal the position of the eyes in the orbits during fixation rather than simply the fact that the animal is fixating. Many convey eye-position signals whether the animal is engaged in a visual fixation task or is simply making eye movements in a totally dark room between trials (170). Fixation neurons do not distinguish the affective nature of visual objects, being equally active for aversive, neutral, or pleasurable stimuli (165). The increments in tonic activity that occur when the animal makes saccades into the gaze field begin after the saccadic eye movement (12). Eye-position cells are found in about equal numbers in areas 7a and LIP (187).

Fixation cells have a variety of gaze fields: some show monotonically increasing activity for a particular gaze direction (8a, 170); others have peaks of activity at intermediate eye positions, and a few have more complex gaze fields (8a). The cells also appear to be selective for fixation in depth (122, 170); however, the eye-position recordings in these studies were made with electrooculographic techniques that sum the horizontal eye position across both eyes. Because the vergence angle could not be determined under these conditions, it is unclear whether these cells were encoding vergence or disparity.

Robinson et al. (162) found that many fixation cells responded to visuosensory stimuli. These were important findings because they pointed to the need for additional control experiments to elucidate the properties of IPL neurons. Robinson et al. argued that the apparent fixation-related activity could be an artifact of visual stimulation, reasoning that the cells with foveal receptive fields were activated by the fixation point functioning as a visual stimulus. They also believed that the gaze fields could result from stimulation of the visual receptive fields by the visual background so that fixations at some positions would bring contours of the test chamber into the receptive fields and activate the neurons.

Subsequent studies have shown that the fixation neurons do convey nonvisual eye-position information. The fixation neurons demonstrate changes in activity when the animal fixates different remembered locations in total darkness, i.e., under conditions in which there is neither a visual background nor a fixation target to activate the neurons [Fig. 11; (8a, 170)]. In a lighted environment the animal can be made to fixate at different angles of gaze by changing the power on spectacles fitted with rotary prisms (Fig. 12). The fixation point remains at the same location

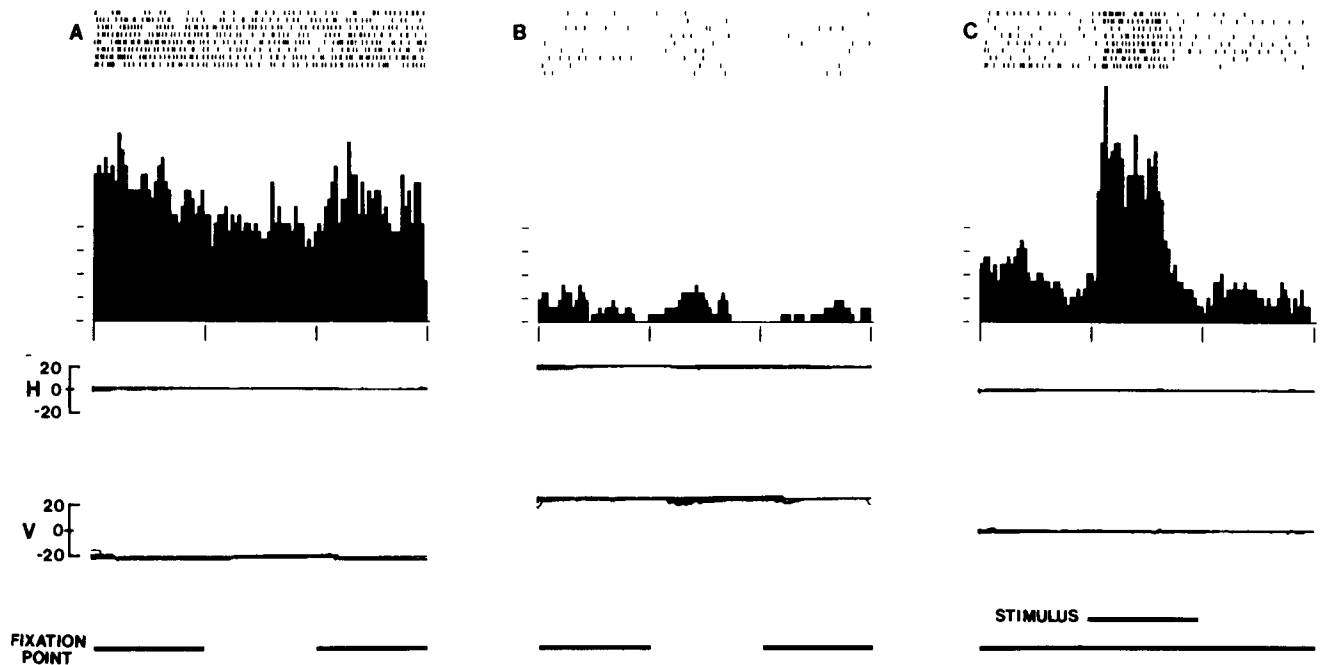

FIG. 11. Demonstration of eye-position-related and visual-related responses recorded from same inferior parietal lobule neuron. *A*: animal fixates small light located 20° down from straight ahead in otherwise total darkness. *Fixation-point line* indicates times when light was on and off. *Lines H* and *V* show horizontal and vertical eye-position traces in degrees of visual angle (animal has been trained to maintain steady fixation even with fixation light off). *B*: same as *A*, but animal fixates target 20° down and 20° right. Tonic rate of activity in *B* is markedly reduced from that in *A* even when fixation light is off, indicating that cell is signaling eye position. *C*: animal fixates target, which does not blink off; a second test stimulus is flashed in visual field evoking visual-related response. Ordinate, 4 spikes/division; abscissa, 1 s/division. [From Andersen et al. (8a).]

in space for the different angles of gaze and thus the fixation point and visual background are at retinotopically identical locations for the different gaze angles. The fixation cells maintain their relation to the position of gaze using this prism control [Fig. 12; (8a)]. Thus it can be concluded that these neurons convey an extraretinal eye-position signal. However, 80% of the cells that exhibit true eye-position signals as indicated by these controls also were found to have visual receptive fields that were mapped with flashed stationary stimuli. The remaining 20% could not be activated with the stimuli that were used to map the receptive fields. In conclusion, most fixation cells have both visual and eye-position-related responses.

It is possible that fixation cells encode the angle of regard with respect to the body rather than with respect to the head. Such encoding would require combining both eye position in the orbit and head-position information. Because the head was fixed in all of these studies, it can only be said at this time that IPL neurons encode at least eye position in the orbit.

SMOOTH-PURSUIT (TRACKING) ACTIVITY. Mountcastle and co-workers (105, 124) first described neurons active during smooth-pursuit (tracking) eye movements but not during static fixations. They concluded that the tracking target should be an object of

interest to the animal, such as food when hungry or the target light with promise of juice reward in the tracking task. They found the tracking neurons to be almost always directionally selective. Figure 13 illustrates this directional selectivity. The illustrated cell is active for tracking from left to right (*left panel*) but is totally inactive for tracking right to left along the same movement path (*right panel*). The activity of the tracking neurons was generally found to increase after the onset of the stimulus for tracking but before the first smooth-pursuit eye movement. It was interpreted that the activity preceding the movement indicated a command to initiate pursuit, although Robinson et al. (162) alternatively proposed that the cells were simply demonstrating a sensory response to the moving stimulus. Like fixation neurons, tracking neurons were reported to be non-light sensitive and to have their activity suppressed during saccades.

Robinson et al. (162) also reported cells showing pursuit activity in the IPL. They found these neurons to be responsive to visual stimuli and argued that the tracking-related activity was in fact due to visual stimulation. They postulated that the cells could be activated either by the visual background moving in the direction opposite to the eye movements or by "retinal slip," small movements of the image of the tracking target on the retina due to errors in matching eye velocity with target velocity.

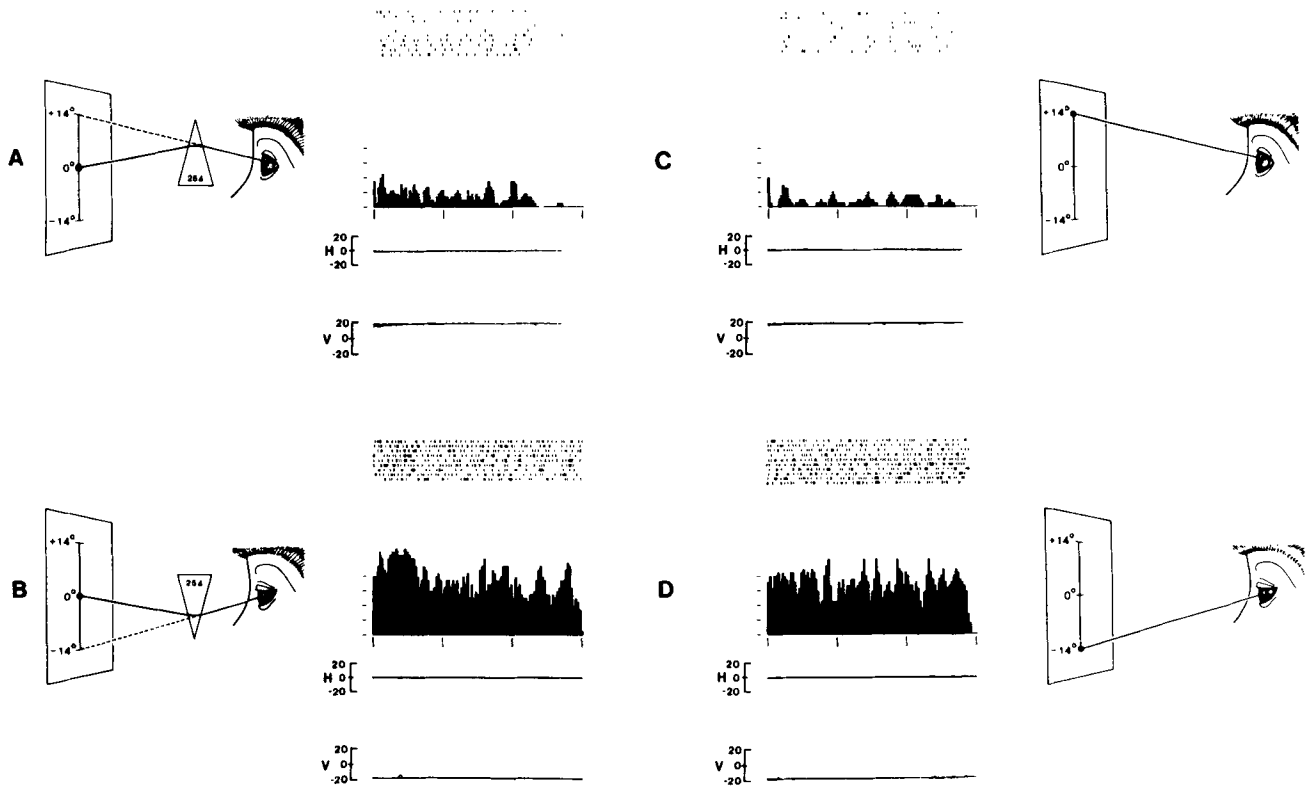

FIG. 12. Task for demonstrating eye-position-related activity. *A* and *B*: animal fixates (with head fixed) point of light in center of screen through two 25-diopter prisms. *A*: prisms are base down so animal must look 14° up from straight ahead to fixate target. *B*: prisms are base up so animal must look down 14° . *C* and *D*: prisms are removed and animal is made to look 14° up (*C*) or 14° down (*D*) by moving fixation point up or down on screen. Angles of gaze are identical for *A* and *C* and for *B* and *D*; retinotopic positions of visual background are identical in *A* and *B* but different in *C* and *D*. Recording data indicate that cell activity varies with eye position but not with changes in retinotopic location of visual background. Lines *H* and *V*, horizontal and vertical eye positions measured in degrees of visual angle. Ordinate, 5 spikes/division; abscissa, 1 s/division. [From Andersen et al. (8a).]

Sakata et al. (171) extended work on the tracking neurons. In their recording experiments, 80% of the tracking neurons were active while the monkey tracked a spot of light in otherwise total darkness, i.e., under conditions in which no spurious sensory stimulation from the movement of the visual background crossed the retina. To ensure that retinal slip was not activating these cells visually, they employed an additional control in which the tracking target was turned off for brief periods during smooth pursuit. Their animals maintained tracking in these targetless periods, and the cells maintained their eye-movement-related activity.

Wurtz and Newsome (219) examined cells in the MST that respond to moving stimuli while the animal tracks a target in otherwise total darkness. In the course of smooth pursuit the tracking target was stabilized on the retina by using the recorded eye-position signal to move the target. The pursuit activity was maintained under these open-loop conditions. Because retinal slip is minimal in the open-loop situation, it is unlikely that it was driving these cells (Fig. 14). Moreover, in nearby area MT, cells with foveal receptive

fields became active in the tracking tasks but always fell silent under the open-loop tracking conditions, as would be expected for exclusively visual motion-sensitive neurons. In light of these experiments and those of Sakata et al. (171), it can be concluded that the tracking neurons have both visuosensory-related and nonvisual, smooth-pursuit-related activity.

The visual motion sensitivity of the tracking cells can be either in the same (isodirectional) or in the opposite (antidirectional) direction for tracking (162, 171). Sakata and co-workers suggested that the antidirectional cells contribute to the perception of motion. These cells have been shown to be much less active in the dark, presumably as a result of the absence of visual background. In lighted environments the retinal image of the background moves in the direction opposite to tracking and thus would further activate the antidirectional cells during smooth pursuit. This observation may explain why the perceived velocity of a tracked target is always underestimated when the visual background is removed (179). The tracking component of perceived target motion probably originates from an efference copy of the smooth-

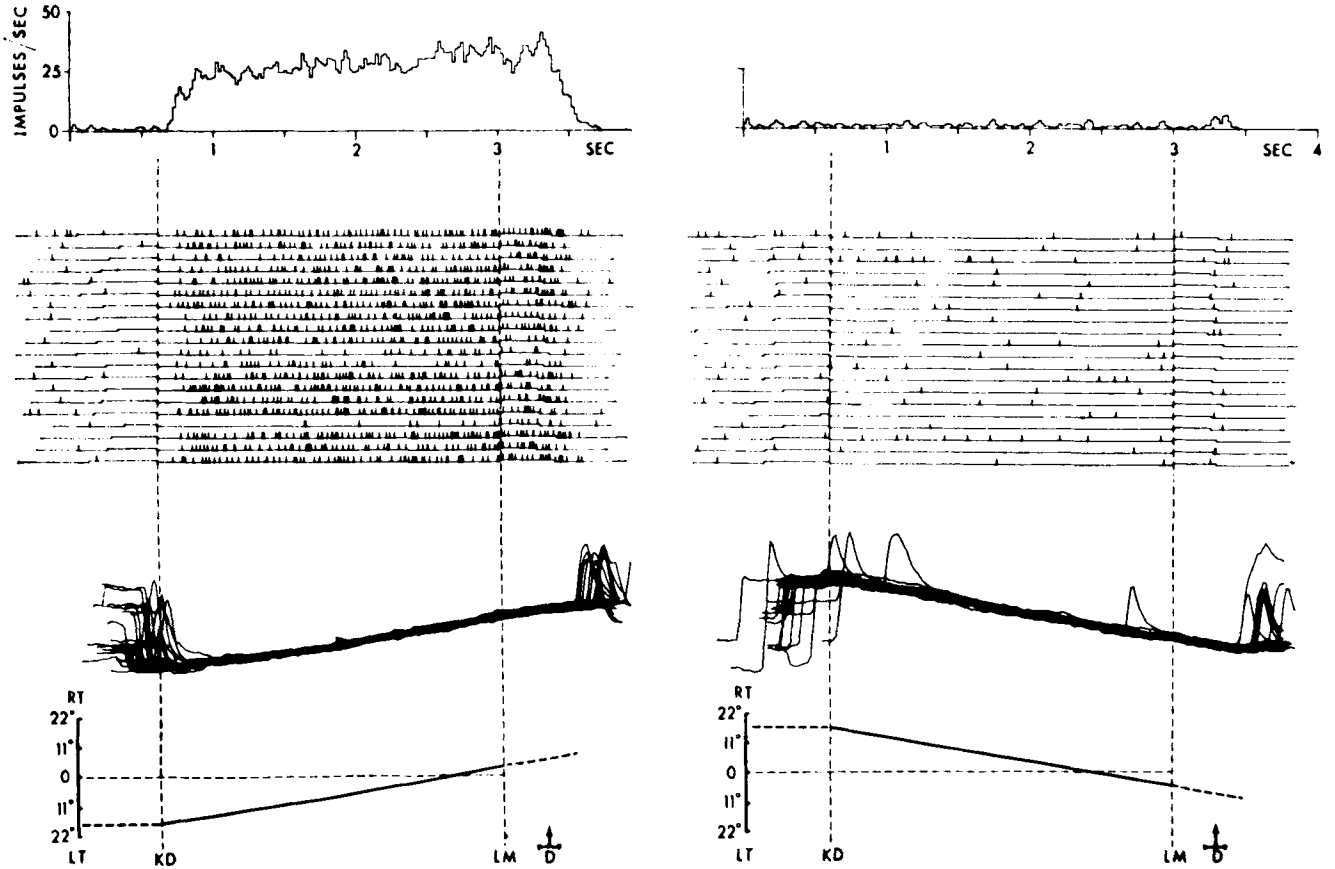

FIG. 13. Example of smooth-pursuit-related activity. *Left*, animal tracks point of light moving left to right $9^\circ/s$. *Right*, animal tracks in opposite direction. Histograms at top of figure are made from spike rasters immediately below; below rasters are eye-position recordings; below eye-position recordings are graphs showing position of fixation point with respect to time. KD, time at which animal pulls back behavior key and target begins to move; LM, time at which target light dims, signaling animal to push key forward; D, mean reaction time. [From Mountcastle et al. (124).]

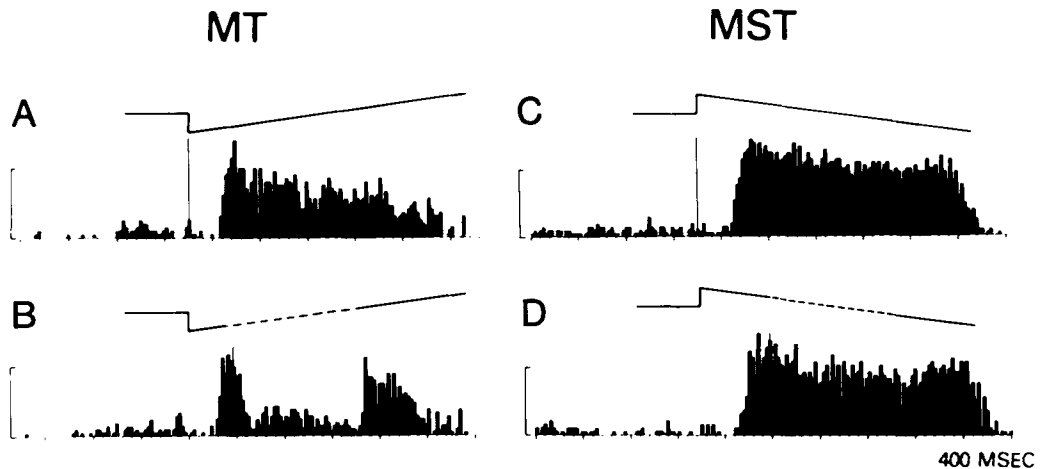

FIG. 14. Demonstration of pursuit-related activity for medial superior temporal (MST) area neurons but not for middle temporal (MT) area neurons. *A* and *C*: animal tracks spot of light; *line* above histogram indicates position of tracking target vs. time. *B* and *D*: *dashed lines* of target-position record indicate times at which tracking target was stabilized on retina and animal maintained smooth pursuit. Decreased activity of MT neuron during stabilization indicates that its activity was mainly due to visual stimulation resulting from movement of target image on retina. Maintained activity of MST neuron during stabilization indicates that cell has pursuit-related activity not due to visual motion stimulation. (R. H. Wurtz and W. T. Newsome, unpublished observations.)

pursuit command because passive movement of the eye by external manipulation in the dark does not cause the perceived movement of an afterimage, whereas active tracking of the afterimage does make it appear to move (107).

Sakata et al. (169) also proposed that the antidirectional cells may play a role in "induced" motion. Moving a frame around a fixated stationary point in the dark leads to the perception that the point, and not the frame, is moving in the direction opposite to the actual movement of the frame (55). The antidirectional neurons are activated by a frame around the fixation point moving in one direction or, in the absence of the frame, in pursuit of the fixation point in the opposite direction in the dark (169). To summarize, antidirectional tracking neurons in the IPL could boost sensitivity to perceived motion by combining the efference copy of the tracking command with the visual stimulation that comes from movement of the surround in the opposite direction during tracking.

Most tracking cells recorded by Kawano et al. (88) gave the same response whether the animal tracked the stimulus solely with his eyes (with head fixed) or during vestibular ocular-reflex cancellation, in which case combined eye and head tracking maintained the eyes in a fixed orbital position. The cells appear to behave like cerebellar Purkinje cells, which encode gaze velocity by vectorially adding head velocity (derived from the vestibular apparatus) to the velocity of the eye moving in the orbits (99, 100, 118). Like Purkinje cells many of the parietal cells do not respond during chair rotation in the dark when eye velocity is approximately equal and opposite to head velocity, as a result of the vestibular ocular reflex. However, if the animal fixates an earthbound fixation point during chair rotation in the dark, the parietal cells give a definite, although much smaller, response than that seen in eye-tracking or combined eye- and head-tracking tasks. This result suggests that a component of the response is due to small motions of the fixation target on the retina, which result from imperfect stabilization of the image. These tracking cells recorded by Kawano et al. (88) probably correspond to the isodirectional neurons of Sakata et al. (171). The eyes generally trail behind a constant-velocity target during pursuit, and, as a result, pursuit and retinal slip are usually in the same direction. Thus the cells appear to encode target velocity by adding head velocity, eye velocity, and retinal-slip velocity. In the few cells that have been examined in detail by Kawano et al. (88), the velocity signal appears to be nonlinear, saturating at high velocities. Further investigation is needed to determine how these spatially synthesized signals contribute to smooth-pursuit behavior and motion perception.

SACCADIC ACTIVITY. Mountcastle and co-workers (105, 124) reported saccade cells that were active when an animal made purposeful saccades to follow the jump of a fixation target but were not active when the

animal made spontaneous saccades. The activity was reported to precede the actual eye movement by an average of 55 ms. Saccade cells were found to be selective for the direction of the saccade but not the amplitude. Like fixation and tracking neurons, they were reported to be non-light sensitive. Some saccade cells also showed a positional dependence, with saccadic activity varying for saccades of the same amplitude and direction but initiated from different orbital positions (222).

Robinson et al. (162) noted that saccade cells also respond to visual stimuli. They reasoned that the saccade-related activity was actually a sensory response either to the appearance of the saccade target or stimulation from the background during eye movements. Using tasks in which animals in total darkness make saccadic eye movements to remembered locations, it has been shown that IPL cells have saccade-related responses that are not simply a result of visual stimulation (125). Again, however, over 80% of these cells do have visual receptive fields (8a). Andersen et al. (8a) reported that only 5 of 46 saccade-related neurons had activity preceding the eye movement and that the median latency for the beginning of saccade-related responses was 75 ms after the beginning of the eye movement. Earlier reports of activity preceding eye movements may have been due to a visual response evoked by the onset of the saccade target.

In conclusion, work on saccade, smooth-pursuit, and fixation neurons following Mountcastle's pioneering studies has revealed that many of the cells with motor-related properties are also strongly driven by sensory stimuli. Robinson et al. (162) questioned whether the behavior-related responses reported by Mountcastle and co-workers were not in fact artifacts of sensory stimulation resulting from movements or from stimulation by the visual targets for the movements. Later and more highly controlled experiments have revealed that IPL cells demonstrate both sensory and motor components in their responses.

SOMATOSENSORY AND REACH ACTIVITY. In Mountcastle's initial studies, cells activated by somatosensory stimuli were reported to be located largely in area 5 and not in area 7a (124). Subsequent studies outlined in *Functional Subdivisions*, p. 489, (10, 79, 81, 159, 160, 162) have shown that area 7b also contains predominantly neurons activated by somatosensory stimuli. Mountcastle et al. (124) found two-thirds of area 5 neurons to have activity related to the joints. Many of these neurons signaled the static angle of the joint. Most were related to a single contralateral joint, but 10% were related to two or more joints and 7.5% were related to ipsilateral joints. The remainder of area 5 neurons were activated by cutaneous, deep-tissue or muscle stimulation. Their cutaneous receptive fields were large, and many specifically responded to stimuli moving in a particular direction.

Mountcastle et al. (124) also defined in areas 5 and 7 a class of neurons, sometimes known as "reach"

cells, that respond to active arm projections or hand manipulations. They were generally active for movements of the contralateral limb; the few cells that were active for both limbs or the ipsilateral limb were mainly located in area 7. These cells appeared not to be active for somatosensory stimuli and to respond only to limb movements directed to objects of interest to the animal, such as pieces of food or the reward panel in the reaching task. During the reaching task some cells were found to be active before the animal released the key to make an arm projection to the press panel; i.e., cell activity preceded any limb movement. The pattern of activity for projection or reach neurons appeared to be independent of the angle of the spatial trajectory with respect to the body.

Again Robinson et al. (162) believed that reach cells were responding to sensory stimulation, in this case of a somatosensory nature, and not to the motor behavior of reaching. Subsequent experiments have shown movement-related responses in area 5 that are not an artifact of somatosensory stimulation. Two-thirds of neurons sampled in recording experiments in area 5 have been found to be active prior to arm movements triggered by visual or auditory stimuli (41, 86). Many of these cells have changes in activity that precede the earliest changes in electromyographic recordings from the muscles involved in the movement. Thus the neural responses cannot be a result of somatosensory stimulation due to movement. Moreover, when the trained limb is deafferented by dorsal rhizotomy, a substantial number of cells in area 5 are still activated by its movement, whereas all cells of the primary somatosensory cortex are inactivated (28, 176, 177). The onset of area 5 responses are 60–70 ms later than the onset of responses recorded from the primary motor cortex (28, 86, 176). These movement-related responses are therefore likely to be efference copy of motor commands relayed from the frontal lobe rather than commands initiating motor movements.

Kalaska et al. (86) found that 71% of the movement-related neurons that showed activity preceding electromyogram changes could also be driven by somatosensory stimuli; this was the same proportion of neurons from their entire data sample with somatosensory sensitivity. In agreement with these results, Chapman et al. (41) found that 84% of the neurons from which they recorded activity prior to movement also had somatosensory receptive fields. It can be concluded that, like the fixation, saccade, and tracking neurons of the IPL, area 5 neurons have both sensory-related and motor-related activities.

Most area 5 neurons show directional selectivity in limb-movement tasks (41, 86). The directional tuning curves are very broad and explain why Mountcastle et al. (124), who used small differences in direction in their task, saw little change in activity with direction of movement.

VISUAL SENSITIVITY. “Visual” neurons in the parietal cortex are any neurons that have sensory responses to

visual stimuli. These cells often have eye-position-related or eye-movement-related activity as well and thus form an overlapping set with the saccade, smooth-pursuit, and fixation cell types.

The visuosensory properties of IPL neurons were first studied in controlled experiments by Yin and Mountcastle (221) and Robinson et al. (162). In these experiments the animal was required to fixate a point of light, and a second stationary or moving light was then used to determine receptive-field properties of the cells. These and subsequent studies have demonstrated that parietal neurons have very large receptive fields that, when tested with flashed stationary stimuli, are found to be generally homogeneously excitatory throughout their extent (although some inhibitory or off responses are also found). The cells have the strongest responses near the center of their receptive fields, with 30 degrees from the center being the average width for a reduction in responsiveness to one-third of the maximum (8a). The receptive fields can occur in either the ipsilateral or contralateral visual fields and more often than not are bilateral. Whereas many extrastriate visual areas magnify the foveal region, the visual receptive fields of parietal neurons appear to give a more even representation of both the foveal and peripheral visual fields. Motter and Mountcastle (122) have also reported a “foveal sparing” in which the fovea is specifically excluded from the large receptive fields of some visual cells. The neurons are generally not selective for orientation, shape, or color but do appear to be selective for direction of motion and for specific types of relative motion. These motion-sensitive properties are discussed in **VISUAL MOTION SELECTIVITY**, p. 504.

ANGLE-OF-GAZE EFFECTS ON LIGHT SENSITIVITY. Increasing evidence indicates that motor movements to visual targets, particularly rapid movements such as saccades and ballistic reaching, are programmed in spatial rather than retinal coordinates (69, 70, 112, 161). The reason is obvious: movements such as reaching are made to locations in space with respect to the body. The problem arises that visual inputs are framed in retinal coordinates. Thus changes in eye position will change the retinal locations of targets while their spatial locations remain the same. Because it is simple to make accurate movements to extracorporeal visual targets independent of the exact position of the eyes in the orbits, the nervous system must at some point transform the visual representation from retinal-centered to head-and-body-centered coordinate frames.

Humans appear to perceive the world in spatial coordinates. As a result the environment appears stable despite the fact that a person makes two or three eye movements per second. Representations of visual space in the brain must take into account changes in eye position to maintain this perceived spatial constancy. The process of matching change in eye position to change in retinal position does not appear to require extreme precision to generate this perceived spatial

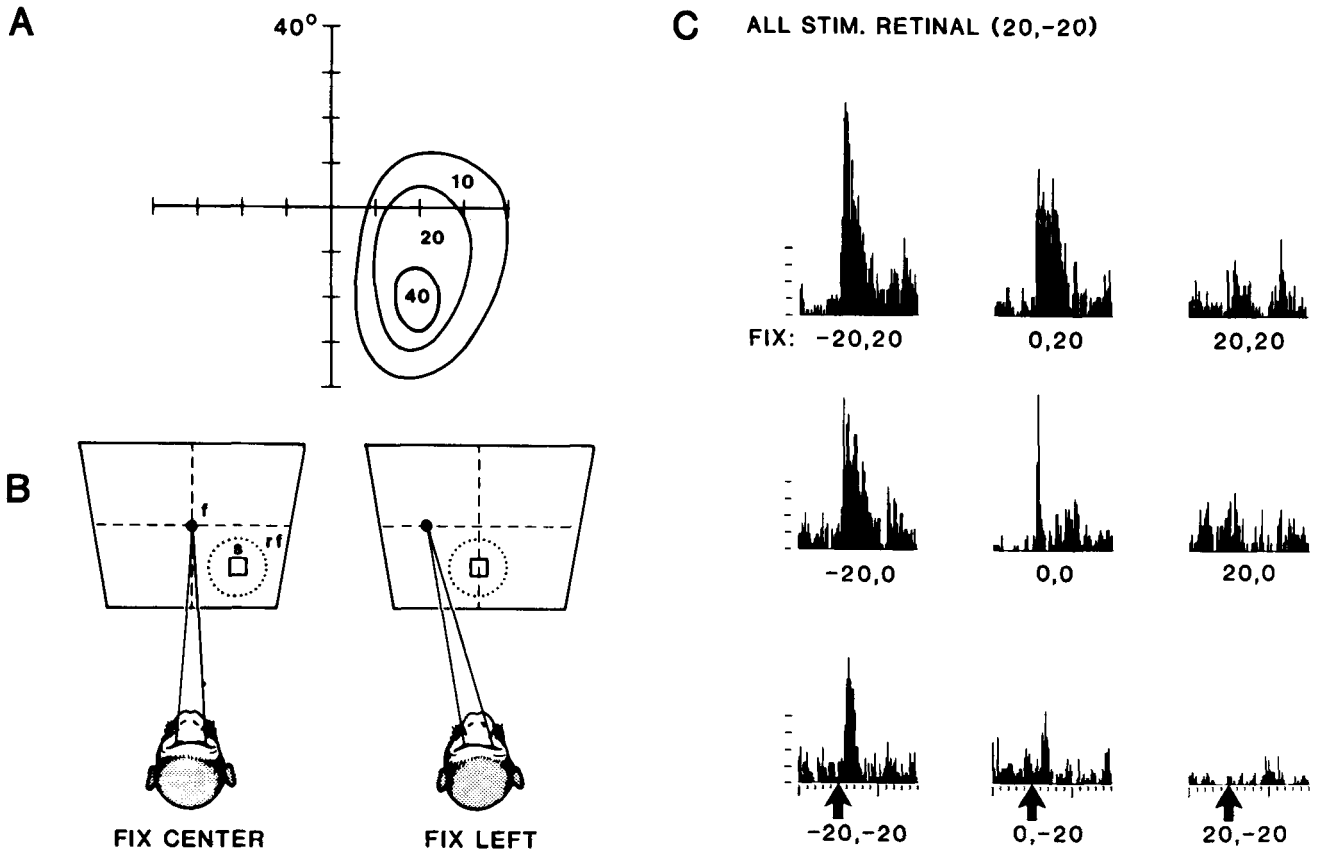

FIG. 15. Example of visual sensitivity of visual parietal neuron changing with eye position. *A*: visual receptive field of neuron plotted in coordinates of visual angle (with animal always fixating straight ahead). *B*: method of determining effect of eye position on visual sensitivity. Animal, with head fixed, fixates (*f*) at different locations on screen. Stimulus (*s*) is presented in center of receptive field (*rf*). *C*: poststimulus histograms corresponding to fixation locations (*fix*) on screen at which responses were recorded for retinotopically identical stimuli presented in center of receptive field. Ordinate, 25 spikes/division; abscissa, 100 ms/division; arrows, onset of stimulus flash. [From Andersen et al. (8).]

constancy (33, 108) so that remapping from retinal to spatial coordinates seems physiologically plausible. Psychophysical measurements show that the perceptual system is less precise than the motor system in calculating spatial locations (59, 78, 109, 190).

The spatial deficits that result from IPL damage in either humans or monkeys indicate that the IPL is a probable location for nonretinal spatial representations. Of particular relevance are the errors in reaching that are common with parietal lobe lesions.

Andersen and Mountcastle (9) first noted visuosensory cells in area 7a whose evoked response for retinotopically identical visual stimuli changed when the animal fixated at different angles of gaze. Such an effect would be predicted if these cells encoded the location of visual stimuli in other than retinotopic coordinates. In a subsequent study, Andersen et al. (8) investigated the possible role of this angle-of-gaze effect in the encoding of spatial location (Fig. 15). They found that the receptive fields of these cells remained retinotopic and the sensitivity of the retinal receptive fields changed as a function of the angle of

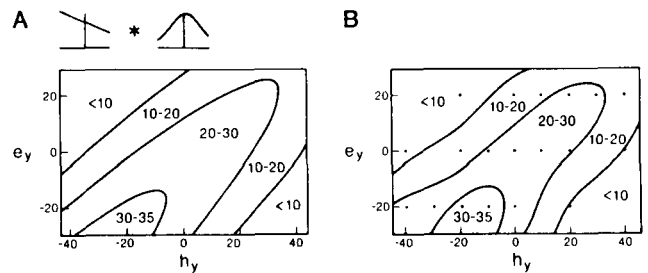

FIG. 16. Demonstration of spatial tuning by area 7a neurons. Gain linearly related to vertical eye position is multiplied by Gaussian function used to fit sensitivity profile along vertical axis through center of visual receptive field. *A*: computer simulation of response (in spikes/s) represented on contour plot. Abscissa, head-centered coordinates of stimulus (h_x); ordinate, eye-position coordinates (e_y). *B*: plot of actual recording data for cell with same gain-field and receptive-field characteristics as model neuron plotted in *A*. [From Andersen et al. (8).]

gaze. This interaction is modeled in Figure 16A as a multiplication of a gain factor that is a function of the angle of gaze and a Gaussian function used to fit the sensitivity profile of an area 7a receptive field. Figure

16A shows a computer simulation of the predicted response of the cell, plotting eye position on the abscissa and stimulus position in head-centered space on the ordinate. (For simplicity only vertical eye and spatial positions are considered.) The model predicts that the cell will be tuned for a location in head-centered space, but the response depends on eye position. Figure 16B illustrates actual recording data for a cell with gain and receptive-field properties similar to those used in Figure 16A. The data fit well with the prediction.

A spatial tuning to location in space independent of eye position was not found at a single-cell level in the IPL. Such information can be shown to be contained within the group response of the cells; however, it is not yet known how the brain reads out this information. In these "coarse-coding" algorithms a feature is encoded with the activity pattern of a population of neurons (14, 76). Receptive fields are built from continuous parameters (in this case, eye position and retinal position), and each of these parameters defines a dimension in the feature space (location in head-centered space in this instance). Because area 7a receptive fields are large and overlapping, the feature can be precisely determined with very few neurons. An alternative to the coarse-coding approach would be to map a retinotopic visual-field representation for each eye position so that each cell would respond to only a single eye position and retinal position. This approach would require small receptive fields and a very large number of neurons. The coarse-coding approach would explain the seeming paradox that an area such as the IPL specialized for spatial analysis has such large receptive fields; the large receptive fields allow a smaller number of neurons to be required to accomplish the retinal-to-spatial transformation. The disadvantage of the coarse-coding approach is that it provides poor resolution in determining the location of two or more closely spaced targets (14, 76); however, attentional mechanisms may limit access to such a distributed representation to those visual targets that are behaviorally relevant to the animal.

VISUAL MOTION SELECTIVITY. A major corticocortical pathway involved in motion analysis begins in area V1, progresses by way of area MT to area MST, and terminates in area 7a (see Fig. 8). The first truly directional neurons are found in area V1. About one-third of area V1 neurons are directionally selective (126). They are tuned to the orientation of stimulus edges, and the direction-selective neurons here will respond to movement of the oriented edges in only one of two possible directions orthogonal to the edge. They are concentrated in layers IVb and VI of area V1 and project from there to area MT (53, 101). Most area MT cells are directionally selective and further elaborate on the motion signal in several ways (2, 3, 54, 111, 126, 211, 225). Some cells are selective to the overall motion direction of complex patterns rather

than only to those components of motion orthogonal to the preferred orientation of the neurons (126). Some MT neurons are speed invariant over a wide range of spatiotemporal-frequency stimulus combinations, indicating that they encode the velocity of a stimulus independent of its pattern (126). Area MT neurons also exhibit an opponent center-surround organization for directional selectivity with strong inhibition resulting when motion in the surround is in the same direction as motion in the center (5, 196). The surround mechanisms are large (quite often including the entire visual field) and may play a role in processing motion parallax (important for extracting depth from motion cues) or in distinguishing true object movement from motion generated by eye movements.

Area MT projects to two locations in the parietal lobe: to area MST, which borders area MT medially and is located on the anterior bank of the STS, and to the ventral IPS (area VIP and the ventral aspect of area LIP) (110, 204; R. A. Andersen, R. M. Siegel, G. K. Essick, and C. Asanuma, unpublished observations). Areas MST and LIP in turn project to area 7a. Both areas MST and 7a appear to be involved in processing more complex aspects of relative motion including rotation, size change, and visual flow (122, 167, 172).

The fact that the IPL is important in motion processing and is at the top of the hierarchy of neural substations in the motion-processing pathway is consistent with its proposed role in spatial perception. Much critical spatial information can be extracted from relative-motion cues. For example, motion parallax, occlusion, and size change (expansion and contraction) give information about depth and movement in depth. Discontinuities in flow fields signify borders and thus aid in foreground-background segregation. The three-dimensional structure of objects can, in fact, be completely recovered from motion cues, and the analysis of visual flow during locomotion can provide information helpful in navigating and predicting the "looming" or "time-to-collision" of objects. The next sections discuss several relative-motion responses of IPL neurons.

Motion processing in area 7a. Robinson et al. (162) first described neurons in area 7a that respond selectively according to the direction of motion of a stimulus. Motter and Mountcastle (122) examined area 7a neurons in detail and found the activity of most cells to be directionally selective. Figure 17 illustrates the response pattern of such a neuron. When a visual stimulus (a small square spot of light) swept horizontally along a trajectory of 100° visual angle centered at the fixation point that began contralateral to the recording hemisphere, the cell responded vigorously. When the stimulus passed along the same trajectory in the opposite direction, the cell gave no response. The cell in this figure is typical of many parietal neurons that change their activity as the stimulus passes through the foveal region. When tested with

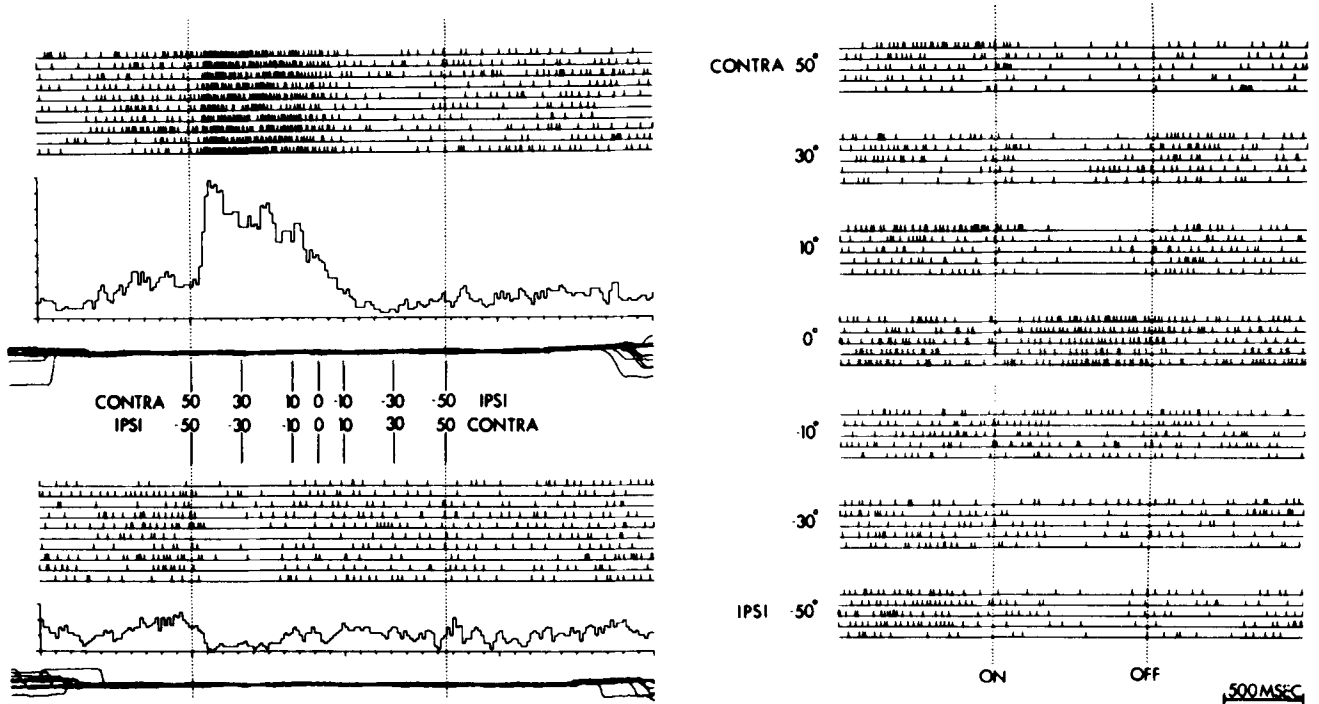

FIG. 17. Directional selectivity of area 7a neuron. *Upper left*: spike raster, histogram, and eye-position recordings illustrate response to visual stimulus moving $60^\circ/\text{s}$ along horizontal meridian (contralateral to ipsilateral). *Lower left*: no response when same stimulus is moved in opposite direction. *Right*: spike rasters show almost no response to same stimulus if stationary and flashed at different locations along horizontal meridian. [From Motter and Mountcastle (122).]

sweeps along the horizontal and vertical axes through the fixation point, 41% of the direction-sensitive cells had different preferred directions in different parts of the receptive field. The preferred directions were usually organized so that movements toward the fixation point gave opposite responses to movements away from the fixation point. An example of this opposed directionality is shown in Figure 18: motion toward the fixation point from any of the four cardinal directions activated the cell under study (*upper panels*); however, as the stimulus passed through the fixation point and proceeded outward (*lower panels*), cell activity ceased. Seventy-five percent of the opposed-motion neurons were active for inward motion; the remaining 25% of the cells with opposed-motion sensitivity responded to outward motion so that the cell began to fire after the stimulus passed through the fixation point. Motter and Mountcastle (122) referred to this structure of directionality as opponent-vector organization. They postulated that these cells play a role in the analysis of visual flow, suggesting that cells with outward activity are maximally sensitive to translation of the eyes forward in the environment, whereas the inwardly active cells respond to translation backward in the environment.

The simplest model for the genesis of these opposed-motion fields depicts the local directional properties that account for their overall organization. Figure 19 shows such a model for a radially organized inward

field. Some cells actually behave in this fashion, with the local direction selectivity (measured as the response moving along a short path) being the same as that recorded when a stimulus moving along a longer path passes through the same region of the receptive field. For many cells, however, the local directionality depends on the previous stimulation of other parts of the field with the moving stimulus, a phenomenon Mountcastle et al. (125) refer to as a "history effect." The spatial extent of these interactions can be quite large, sometimes encompassing the entire visual field (122a).

Rotation information is important for specifying rigid body motion, and size change can be used as a parameter for encoding motion in depth. Sakata et al. (172) reported IPL neurons that appear to be sensitive to the rotation and size change of visual objects. Although these cells were reported to be located in area 7a, many of the recordings were made in the anterior bank of the STS and may have included area MST.

The cell illustrated in Figure 20 responded to clockwise but not to counterclockwise rotation of a vertically or horizontally aligned bar (Fig. 20A, B) or a square (Fig. 20C) but did not respond significantly to sweeps of the bar in the frontoparallel plane (175). This cell's responses did not appear to be concerned with orientation change because two rotating spots gave the same response as the bar (Fig. 20E). More-

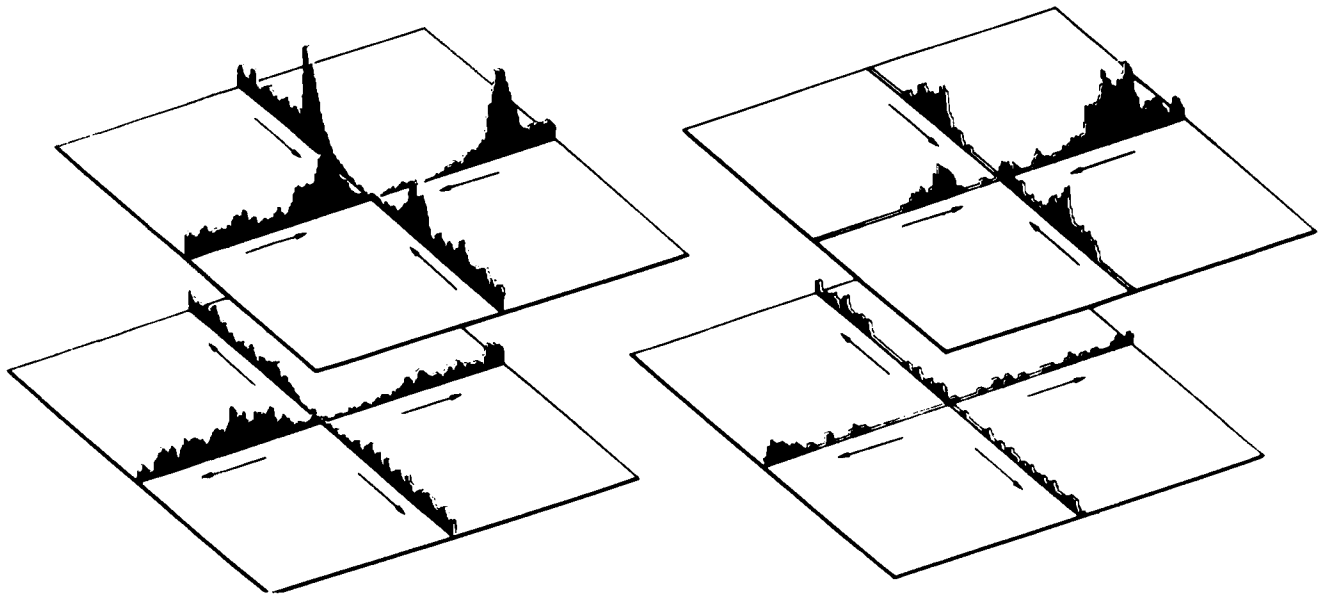

FIG. 18. Two area 7a neurons with opposed directional sensitivity. Histograms depict activity evoked by stimuli sweeping along horizontal and vertical meridians. They were cut in half (at fixation point) and arranged so that *upper panels* show activity when motion was directed toward fixation point and *lower panels* show activity when stimuli had passed through and were moving away from fixation point. In both examples, cells respond only to inward motion. [From Motter and Mountcastle (122).]

over movement of either of the spots alone (Fig. 20F, G) did not activate the neuron, indicating that to fire the cell, the relative movement of the two points was required. To determine whether these cells are truly sensitive to curvilinear motion, it will be necessary to show that they fail to respond to shearing motion. Neurons were also found that were active for rotations in depth in the sagittal and horizontal planes. An example of a cell sensitive to change in the size of a stimulus is shown in Figure 21. Movement of a disk toward the animal activated the cell, whereas disk movement away from the animal did not (Fig. 21B). Expanding the size of a projected circle also activated this neuron, whereas decreasing its size did not (Fig. 21C). Thus this cell and others like it could encode depth change by employing a size-change cue.

Motion processing in area MST. In the first recording experiments in area MST, Van Essen et al. (211) noted that many of the cells in this region were directionally selective for moving stimuli, as were the neurons in adjoining area MT. However, when the investigators passed their electrodes across the myeloarchitectural transition defining the MT-MST border, the receptive fields abruptly changed from the small receptive fields of area MT to the very large ones of area MST.

Saito et al. (167) and Tanaka et al. (196) recorded from a region of MST ~5 mm in diameter adjoining the dorsomedial border of area MT. They referred to this area as the DSR region because cells in this area responded to straight motion in the frontoparallel plane (D cells), size change (S cells), or rotation (R

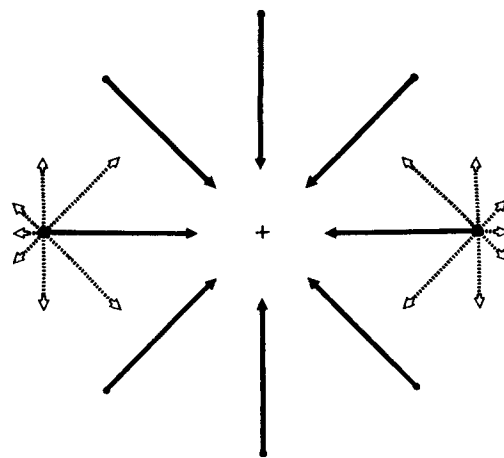

FIG. 19. Simple model for opposed directionality. *Dark arrows*, directional sensitivity for long sweeps of visual stimulus; *dashed arrows*, local directionality (strongest in direction of radial organization). Although some cells show this local directional organization, for many cells, opponent-vector organization for long sweeps results from long-range inhibitory interactions between receptive-field regions. +, Fixation point. [From Mountcastle et al. (125).]

cells). The receptive fields were large and often bilateral.

About one-third of the D cells responded to movement of a bar in a particular direction but did not respond to a large field of moving dots. However, when a field of these dots was moved in the same direction and with the same speed as the bar, the response to the bar was suppressed (Fig. 22, cell 1). In some cases the background field moving in the opposite direction

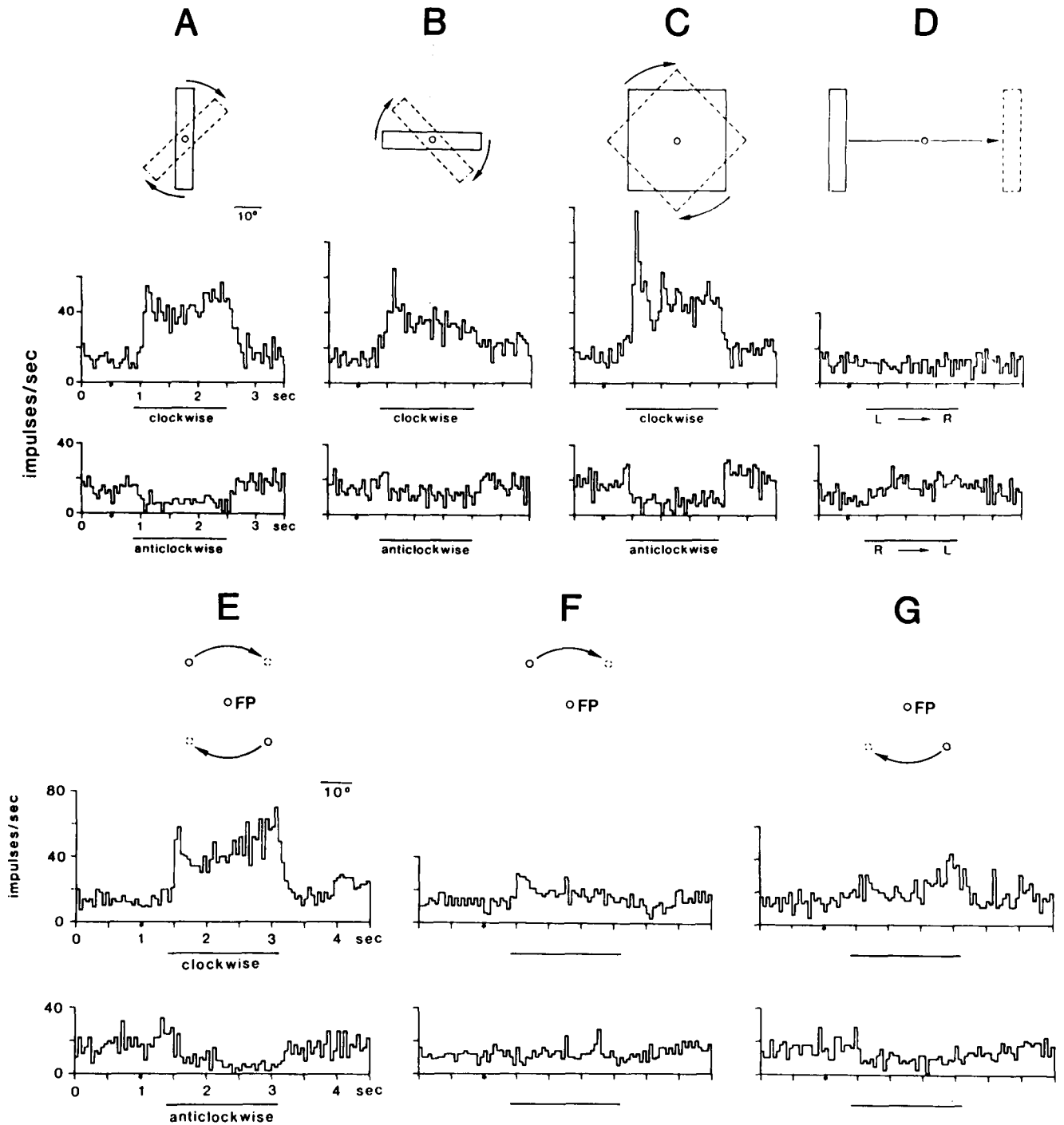

FIG. 20. Example of inferior parietal lobe neuron sensitive to rotation of visual stimuli. *A* and *B*: initially vertical (*A*) or initially horizontal (*B*) bar projected onto screen facing test animal produced response when rotated clockwise but not counterclockwise. *C*: square also produced response only when rotated clockwise. *D*: same bar stimulus as in *A* and *B* did not evoke response when translated horizontally toward right or left. *E*: paired points rotating about fixation point (FP) activated neuron; *F* and *G*: neither point traveling alone in same trajectory produced response. [Adapted from Sakata et al. (168).]

augmented the bar response. These cells had properties similar to those in area MT, but the receptive fields that could be activated with the bar were much larger in area MST. Cells with such properties would

be expected to be maximally sensitive to object movements against a stationary background and would also show stronger responses for increasing amounts of motion parallax. Another third of the neurons were

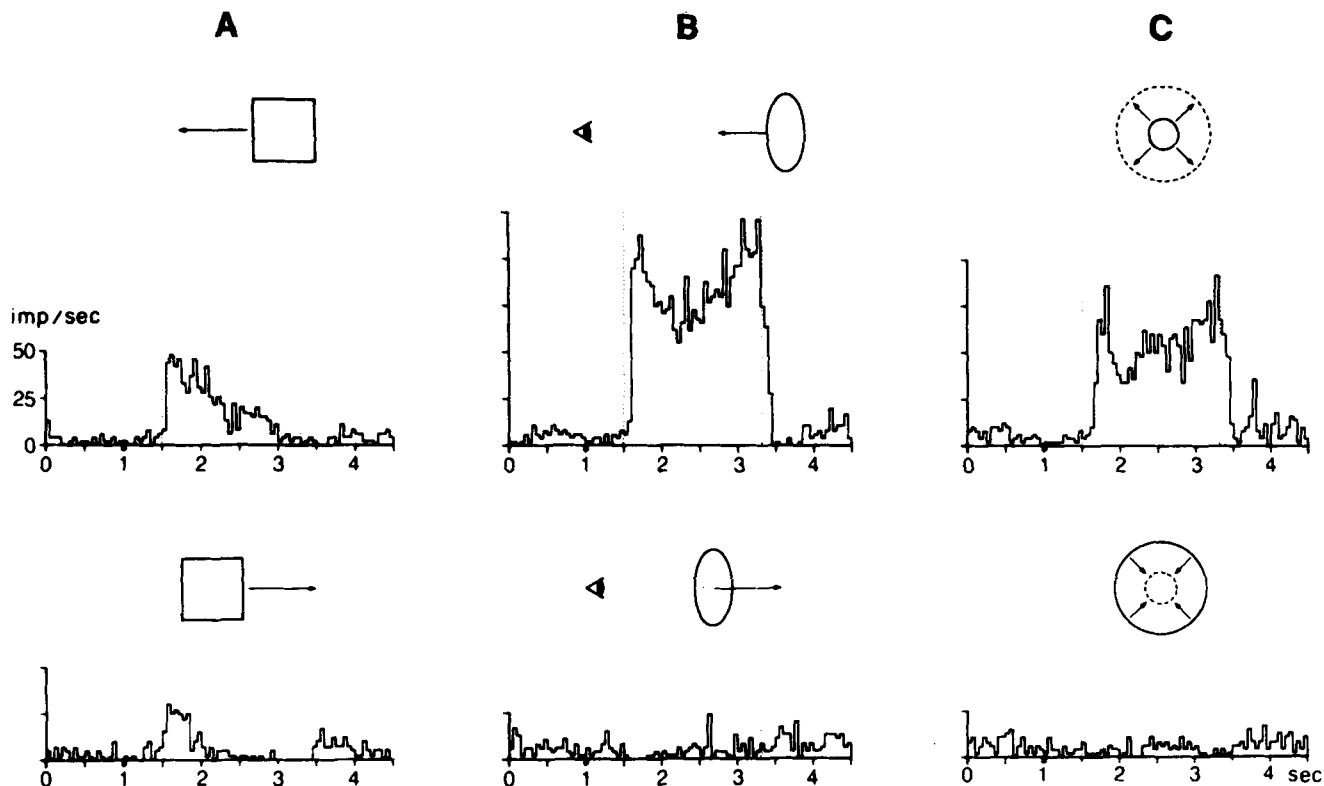

FIG. 21. Example of inferior parietal lobule neuron sensitive to size change. *A*: cell responds somewhat to horizontal translation of visual stimulus in frontoparallel plane, preferring leftward motion. *B*: cell responds much more to stimuli moving in depth toward animal. *C*: expanding size of stimulus also activates neuron; size-change sensitivity at least in part accounts for movement-in-depth sensitivity of cell. [From Sakata et al. (172).]

activated by either the bar or a textured background moving in the same direction (Fig. 22*E, F*). Cells of this type are also found in area MT, but here they have considerably smaller receptive fields. Only one cell of this nonselective group showed opposed directional selectivity for the bar and wide-field stimuli (Fig. 22*J-L*). The final third of the D cells responded only to the large field textured stimuli and were uncommon in area MT (Fig. 22*G, H*). Such neurons would be effective in signaling whole-world movements, which occur during eye rotations, but would not be efficient at detecting object motion against a stationary background. Because these experiments were done in anesthetized monkeys, it is not known whether these neurons also receive smooth-pursuit signals.

Saito et al. (167) also identified neurons in area MST that responded to size change, some cells being excited by expansion of a stimulus and others by contraction. Some cells responded to the expansion or compression of random-dot fields but not to the size change of single luminous stimuli. Such response patterns would suggest that these cells are involved in the analysis of visual flow; this is uncertain, however, because the textured-field stimuli were expanded and contracted by projecting them through a zoom lens,

which also induces a size change of the elements. Saito et al. (167) also reported finding cells sensitive to the rotation of textured disks, most responding to rotation in the frontoparallel plane. Some of these cells were also sensitive to rotations in depth. The depth-rotation cells were found to be active during both monocular and binocular viewing, ruling out stereopsis as a contributing factor. They were also activated by textured patterns rotating on a drum, indicating that a change in the subtending visual angle of the rotating textured object was not a factor.

ATTENTIONAL EFFECTS. Because one of the major symptoms affecting humans with parietal lobe damage is a deficit in visual attention, it is important to study the effects of behavioral state on the response properties of parietal neurons. Yin and Mountcastle (221, 222) and Robinson et al. (162) found that light-sensitive cells in the IPL increased their visual response if the stimulus served as a saccade target. This enhancement in light sensitivity occurred only when the saccade target was within the visual receptive field of the neuron, indicating that it was not a result of generalized arousal. The enhancement effect has been studied thoroughly in many areas of the primate visual system (see the chapter by Heilman, Watson, Valenstein, and

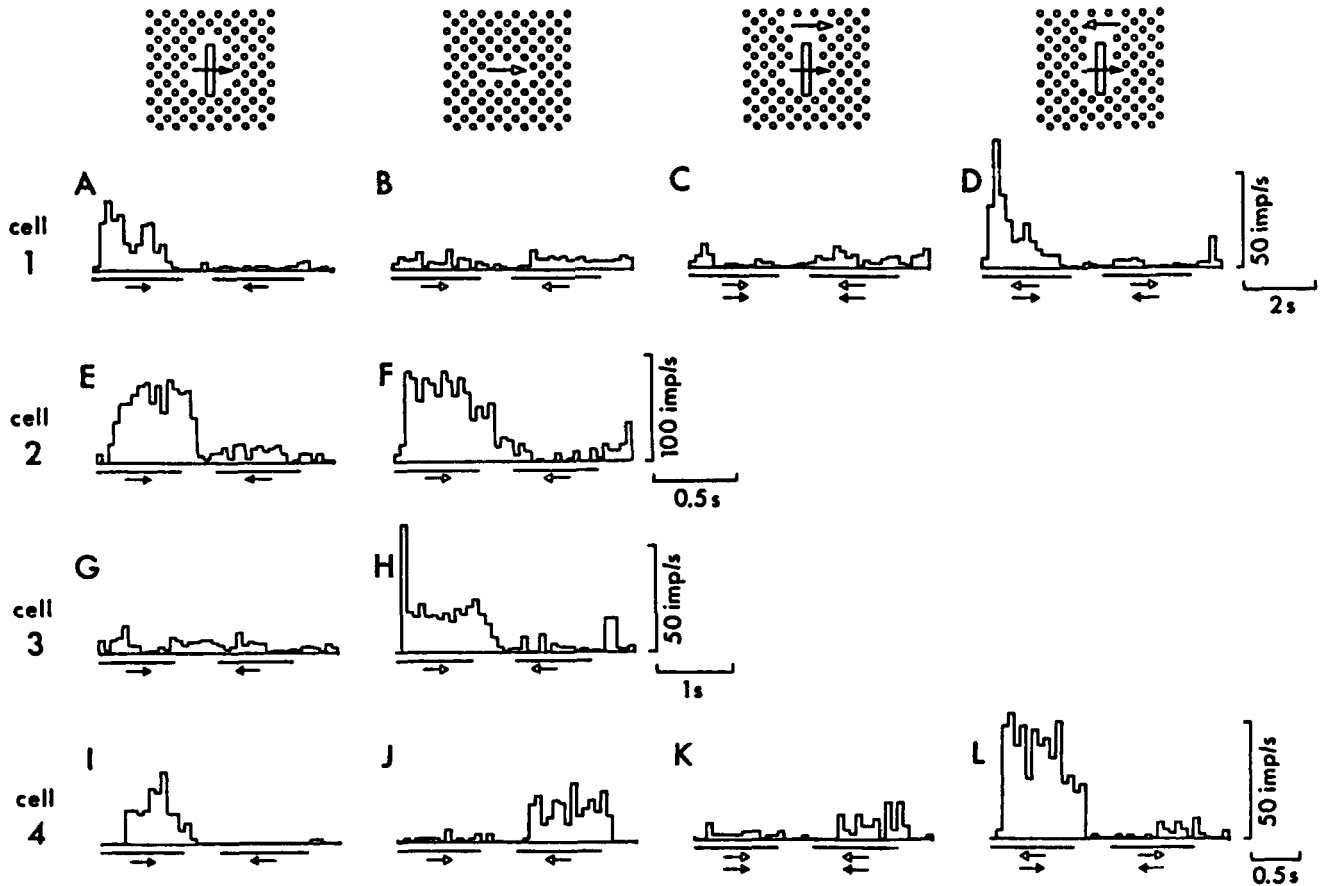

FIG. 22. Responses of four D cells recorded in medial superior temporal area to various combinations of foreground and background movement. A, E, G, I: bar moved over stationary dot-pattern background. B, F, H, J: background was moved without bar present. C, K: bar and background are both moved in same direction. D, L: bar and background are moved in opposite directions. [From Tanaka et al. (196).]

Goldberg in this *Handbook*). The major distinguishing feature of enhancement for parietal lobe neurons is that whereas saccades must be made for enhancement to occur in several oculomotor areas, in the IPL it is sufficient for the animal simply to attend to the visual target and, for instance, to detect its dimming (38).

Mountcastle et al. (123) have found that the behavioral state of the test animal importantly influences the responsiveness of light-sensitive neurons. They tested the light sensitivity of the neurons' receptive fields using a probe stimulus that the animal had been trained to ignore. Light sensitivity was assessed in three behavioral conditions: in the first state (no-task state) the animal was alert but performing no task; in the second state (intertrial-interval state) the animal performed a fixation dimming-detection task, but light sensitivity was tested in the 1 or 2 s between trials as the animal awaited the onset of the fixation point to begin another trial; in the third state (task state), light sensitivity was tested during a task in which the animal maintained fixation of a small spot of light and released a key when the light dimmed to receive

a reward. In the last two conditions the arousal level was likely to be equivalent because the intertrial interval was of random length and once the target appeared the animal was given only a short time to fixate on it and pull back a lever. In other words, the intertrial interval was also a reaction-time task, although different from the fixation task. Interestingly light sensitivity was increased only during the fixation task and not in the other two conditions. The facilitation was not a result of a sensory interaction between the fixation target and the test stimulus. In cases in which the fixation point was turned off for 1 s during the trial but fixation was maintained, the response to the probe stimulus remained the same as when the fixation light was present.

For sensory-guided motor behavior, sensory inputs after suitable processing lead to motor outputs. Thus many of the sensory-related responses to stimuli triggering motor outputs recorded in the IPL may become motor commands at subsequent levels in the nervous system. There is some evidence that these IPL sensory responses have already been elaborated in ways other

than those pertaining to attention. Lamarre et al. (93), for example, identified IPL neurons that responded to a visual cue when the cue triggered an arm movement but not when it triggered an eye movement. However, because the animal was rewarded for the arm movements without eye movements and the eye movements without arm movements were obtained by withholding the reward over many trials, one cannot rule out the possibility that attentional factors account for the different responses. Mountcastle et al. (125) recorded enhanced sensory responses to visual stimuli if they were saccade targets. In these experiments the stimuli were always the same and were presented at the same locations in the receptive field; however, in half the trials the fixation target disappeared with the appearance of the saccade target, commanding the animal to make a saccade, and in the other half of the trials the fixation point did not disappear, instructing the animal to withhold the eye movement. Because the trials with and without eye movements were randomly interleaved, the enhanced initial response to the stimulus when the animal made eye movements could not be explained by attentional differences. Also, because the cells only responded when the target was within their receptive fields, the enhancement could not be due to an off response to the fixation point. It would appear that when a stimulus is going to lead to a motor output, some IPL neurons are more active.

Seal and Commenges (176) recorded activity from area 5 neurons when monkeys made arm movements cued by auditory stimuli. They found that some of the neurons that were activated prior to the movement were better correlated with the auditory cue than the movement. These auditory responses did not occur when the sounds were not cues for motor movements, nor has there been any report of auditory sensitivity in this somatosensory area. Because space- or frequency-selective auditory receptive fields were not demonstrated in these experiments, an increase in general arousal linked to the auditory cue cannot be ruled out as the source of this response.

These observations suggest that the sensory-related responses recorded in the posterior parietal cortex may be more abstract than those recorded in lower cortical areas and possibly more closely linked to behavior. However, it would be improper to consider these sensory-related responses as commands for motor movement because the onset of activity is not temporally related to the onset of movement and vigorous sensory responses can be evoked from IPL neurons without ensuing movement.

SPECULATIONS REGARDING ROLE OF IPL IN BEHAVIOR

The preceding sections review the clinical, anatomical, and physiological literature on the IPL. These data form a foundation for various theories pertaining

to the role of this brain region in behavior. Three general theories of IPL function are described next. The first, the command hypothesis, proposes that this area is involved in issuing commands for motor behavior and is largely a motor structure. The second hypothesis proposes that the area is involved in directing attention and serves a sensory-regulating function. The third proposes that the IPL is neither primarily motor nor sensory in operation but is involved in sensorimotor integration. As a corollary to this final proposal, the IPL is postulated to play a role in the transformations of sensory coordinate frames to spatial or motor coordinate frames; such transformations are essential for sensorimotor integration.

Command Hypothesis

Mountcastle et al. (124) initially proposed that the posterior parietal cortex contained a command apparatus that issues commands for exploratory motor activity within the extrapersonal space. The command hypothesis was consistent with their observations that the oculomotor, projection, and hand-manipulation neurons had behaviorally related responses, that their activity often preceded the behavior, that the cells were not activated by sensory stimuli, and that the activity of the neurons depended on the internal drives that initiated the behaviors. The commands were believed to be general in nature; e.g., the projection neurons did not specify the exact parameters of the trajectory; these details presumably were elaborated by motor structures efferent from the posterior parietal cortex. It was proposed that the most prominent deficit after posterior parietal lesions in monkeys, the reluctance to use the contralateral limb, could be accounted for by the loss of the commands from the projection neurons. Oculomotor deficits seen with parietal lesions, such as difficulty in disengaging fixations, instabilities in fixations, and the generation of a series of saccades when attempting to make smooth-pursuit eye movements toward the side of the lesion, could be accounted for by the loss of the oculomotor command neurons.

The fact that most of the cells in IPL can be vigorously driven by sensory stimuli without generating movements would tend to argue against their issuing the commands for movement as originally formulated by Mountcastle et al. (124). However, as Lynch (102) pointed out, primary motor cortex neurons, which are generally believed to issue commands for motor movement, also respond to somatosensory stimuli; thus the presence of sensory activity does not in itself rule out a motor command function. Nevertheless, unlike motor cortex in which movement-related responses usually precede movement, IPL activity of the oculomotor neurons generally follows the initiation of movement, at least in the saccade and fixation neurons (latencies have not been determined for the tracking cells) (8a). Although movement-re-

lated activity in area 5 often precedes limb movement, it is still slower than the movement-related activity of primary motor cortex, suggesting that it is an efference copy rather than a motor command (86, 93). Thus very few neurons in the posterior parietal cortex have the correct temporal sequencing or response properties to support the idea that the area is issuing commands for motor movement.

Attention Hypothesis

A second and widely held hypothesis suggests that the IPL is important for selective attention. Evidence for this proposal comes from both lesion and electrophysiological studies, much of which has been outlined in this chapter. Lesions of the IPL produce the neglect syndrome, which is generally interpreted as an inability to direct attention into the contralateral space. Records indicate that visual parietal neurons are more responsive to a stimulus if that stimulus has behavioral relevance to the test animal. Also, the behavioral act of attentively fixating a target to detect its dimming markedly facilitates the responsiveness of visual parietal neurons.

Although it is clear that attentional mechanisms play an important role in the functioning of the area, three questions remain unanswered. 1) Do selective attentional effects begin at the level of the IPL or at cortical fields earlier in the hierarchy of corticocortical connections? 2) To what extent is the IPL involved in regulating attention; i.e., should it be considered the central controller for all cortical attentional phenomena, or does it play an attentional role only within the confines of the types of functions that it performs? 3) Are the attention-related changes in parietal neuron activity due to neural mechanisms residing within this cortical area, or are they a result of the control of this area by another brain region such as the pulvinar?

In regard to the first question, very little work on attentional mechanisms has been done in extrastriate cortical areas leading into the parietal lobe. From the work of Wurtz and Mohler (218), however, it would appear that attention does not play a role in the functioning of striate cortex, at least with respect to selecting stimuli for saccadic eye movements.

Regarding the second question, selective-attention effects have been shown for area V4 and inferotemporal cortex neurons (121, 158). As mentioned previously, area V4 and the inferotemporal cortex form a large component of the ventral cortical visual pathway that is anatomically and functionally distinct from the dorsal pathway that includes the IPL. Because direct connections between the IPL and area V4 or the inferotemporal cortex are sparse, it seems unlikely that the IPL regulates attentional mechanisms within this pathway. As mentioned in previous sections, the thalamus, and particularly the pulvinar, appears to be a better candidate than the IPL for directing large-scale cortical attentional processes within the visual

system. Lesions of the pulvinar produce deficits in visual search. The thalamus is the major source of input to the cortex, and in turn the cortex projects back onto the thalamus, conceivably controlling its own inputs. Stimulation of the pulvinar has been shown to produce enhanced visual responses in IPL not unlike those that naturally occur when an animal attends to a stimulus (31).

Separate nuclei within the pulvinar connect to different groups of visual cortical fields. Thus pulvinar nuclei may direct processing streams within and between groups of cortical fields that are functionally related. In the case of the medial nucleus of the pulvinar, its thalamocortical structure (outlined in *MEDIAL PULVINAR DISKS AS ONE POSSIBLE ANATOMICAL SUBSTRATE FOR AN ATTENTION MECHANISM*, p. 495) would indicate that activation of one locus within the nucleus would activate a large set of association cortical fields in anatomically specific ways. Most of these cortical areas are likewise reciprocally connected with one another via corticocortical connections, suggesting that they form a functional unit. Lesions at different locations in this cortical circuit produce similar disturbances, suggesting a functional modularity. Crick (44) has proposed that attentional "searchlights" are located in the reticular nucleus of the ventral thalamus and operate on the cortex through their influence on dorsal thalamic nuclei such as the lateral geniculate nucleus and pulvinar.

To infer that the IPL is not the attentional controller of the cortex does not belittle the importance of attentional processes in its functioning. Because the IPL appears to play a major role in sensory-to-motor transformations, attentional mechanisms could play a role in the selection of visual targets for motor behavior. If a coarse-coding approach is used for coordinate transformations (as discussed in *ANGLE-OF-GAZE EFFECTS ON LIGHT SENSITIVITY*, p. 502), then attentional mechanisms would be important in limiting the number of visual objects that have access to spatial maps. Such filtering would ensure accurate spatial localization of visual targets.

In regard to the final question, it is not known whether attentional processes observed in recording experiments are the result of neural mechanisms within or without the IPL. One possibility (outlined in *MEDIAL PULVINAR DISKS AS ONE POSSIBLE ANATOMICAL SUBSTRATE FOR AN ATTENTION MECHANISM*, p. 495) is that the pulvinar exercises regulatory control of the flow of information through the IPL.

Visuomotor Integration Hypothesis

The third hypothesis contends that the IPL plays a critical role in sensory-to-motor transformations. The IPL is proposed to be part of an interface between sensory and motor systems that accomplishes motor movement under sensory guidance (8a). Consistent with this view is the observation that IPL lesions

produce both sensory and motor disturbances. Further support comes from the observations that many classes of IPL neurons have both sensory-related and motor-related responses. The motor-related responses appear in many cases to be efference copies of motor commands rather than actual motor commands. By giving information about eye position and eye velocity (among other things), efference copies may play an important role in transforming sensory coordinate frames to spatial coordinate frames that are necessary for accurate motor behavior. The sensory-related responses may be more complex than those of lower-order cortical fields, being strongly linked to behavior. Thus the sensory responses may represent the early stages of processing along a neural stream that will end in brain areas involved in initiating and maintaining movement.

The smooth-pursuit eye-movement system offers an example of the possible role of the IPL in sensorimotor integration. This system begins in the area V1, where neurons sensitive to motion direction project to the IPL by way of area MT. These areas then project to the cerebellum via the pontine nuclei, and the cerebellum in turn projects onto brain stem motor centers that generate the motor commands for smooth-pursuit eye movements. Lesions to the visual cortex and the peripheral-field representation of area MT produce sensorylike deficits in the ability to judge the speed of the pursuit target. Lesions farther along the system produce a motorlike deficit in which the animal cannot maintain smooth pursuit when the direction of tracking is toward the side of the lesion. It is within area MST that pursuit-related activity is first encountered.

The isodirectional cells of area MST could play an important role in visuomotor integration for smooth-pursuit eye movements. Recall that these cells appear to be integrating retinal-image velocity, eye velocity, and head velocity to give a signal related to the velocity of the pursuit target in the environment. During the initiation of pursuit, these cells are activated by the movement of the target image across the retina. Although at this point in the system the signal is sensory related, farther along the pathway it may become the command to initiate smooth pursuit. Once tracking commences, the retinal-image velocity decreases to almost zero. However, the cells' activity does not decrease because the eye-velocity signal now augments it so that the cells still signal the velocity of the target in space. Centers later in the pathway can use this signal to maintain pursuit by matching tracking velocity to target velocity.

A similar argument can be made for the role of IPL neurons in performing saccades and reaching movements to suddenly appearing visual targets. Making accurate, rapid reaching movements to visual targets requires that the location of the target in space be calculated for which retinal-position, eye-position, and head-position information must be used. Also, recent psychophysical and physiological evidence sug-

gests that saccades are likewise programmed in spatial rather than retinal coordinates. As discussed in ANGLE-OF-GAZE EFFECTS ON LIGHT SENSITIVITY, p. 502, many of the visually responsive IPL neurons integrate eye-position and retinal-position information to produce responses tuned for locations in at least head-centered space. Conceivably, head position also enters into the equation at some point in the involved neural pathways to produce coding for locations in body-centered space. These sensory signals may be further elaborated farther along the neural pathways to become motor commands for initiating movement. Because the population response of parietal neurons encodes the location of targets in at least head-centered space, these signals appear to have been transformed from retinal to spatial coordinate frames at this level. It is this latter coordinate frame that is required for calculating the proper motor commands.

The IPL also plays an important role in spatial perception. Lesions to this area produce spatioperceptual deficits; the spatial transformations that are evident in the responses of parietal neurons could subserve spatial perception and the spatial aspects of motor behavior.

CONCLUSION

Clinical, physiological, and anatomical data presented in this chapter indicate that the posterior parietal cortex plays an important role in visuomotor integration, spatial perception, spatial orientation, aspects of attention, and visual motion analysis. The caudal aspect of the IPL in particular appears to be at the pinnacle of the dorsal visual pathway that is concerned with spatial functions (the "where" pathway). It is both anatomically and functionally distinct from a second major visual pathway more ventral in the hemisphere that is concerned with pattern and color analysis (the "what" system).

The posterior parietal cortex appears to be neither purely motor nor purely sensory in function; it is situated between sensory and motor areas and plays a major role in sensorimotor integration. A generalizing principle of posterior parietal physiology is that its neurons exhibit both sensory-related and motor-related activity. The motor-related activity of at least the reach and some of the saccade cells (those with activity preceding movement) have properties that suggest that they are efference copies of motor commands rather than actual motor commands. These motor-related responses appear to play a role in coordinate transformations of sensory signals. Eye-position signals may play a role in the encoding of locations of visual targets in nonretinal coordinate frames. Similarly, smooth-pursuit-related activity may play a role in the encoding of the velocity of stimuli in space. Aspects of spatial perception are likely to be derived from the same structures that are involved in sensorimotor integration.

The IPL also appears to play an important role in spatial aspects of attention. In humans IPL lesions produce, among other deficits, neglect of the contralateral visual field. Recordings from monkey IPL show that the behavioral state strongly influences the responsiveness of parietal neurons. These attentional effects may be important for selecting stimuli for motor behavior or may limit inputs to spatial representations in the area. However, it may be erroneous to consider the IPL as controlling attentional factors for the entire cortex; a more likely candidate for such a role is the thalamus.

The major pathway for visual motion analysis passes from area V1 through area MT into the IPL. As would be expected, this is also the path of movement analysis for the smooth-pursuit eye-movement system. This pathway should provide a model for studying the role of the IPL in visuomotor integration.

It is now clear that the IPL contains several anatomically and functionally defined cortical fields. This understanding will aid in the further analysis of its function. Visual inputs to the caudal IPL are derived mostly from area V1 by way of multiple parallel pathways through extrastriate cortex.

Among the questions for future research are those pertaining to the spatial processing role of the IPL. Are the eye-position and eye-movement signals recorded in this cortical area derived from proprioception or from corollary discharge? The anatomical pathways by which these movement-related responses reach the IPL are also unclear, although the work of Schlag-Rey and Schlag (173a) suggests that some of the eye-position signals may pass from eye-movement centers in the brain stem through the intralaminar nuclei of the thalamus to the IPL. Although evidence has been found for the tuning of visual cells for spatial locations in the frontoparallel plane, these cells may

also be tuned to location in depth. Sakata et al. (170) reported neurons that appear to signal fixation in depth, with activity possibly related to the angle of vergence. Such a signal could be used in the same manner as the horizontal-vertical eye-position signals for spatially tuning the visual cells. The angle of the head with respect to the body may also contribute to spatial processing in this area, suggesting that body-centered frames are being employed.

More work is required on the motion-processing pathways that pass through the IPL. The use of rigorously controlled motion stimuli should establish whether specific types of relative motion are analyzed by this system. The structure of objects can be determined solely by motion cues. Do these structure-from-motion capacities require interactions between the dorsal "where" pathway that is important for motion processing and the ventral "what" pathway that is important for object recognition, or is the dorsal pathway independently capable of a degree of form analysis, particularly within the motion domain?

More will be learned about the role of the IPS in sensory-to-motor transformations. One particularly interesting subject is the distinct dissimilarity between the spatial performances of the perceptual and motor systems. These differences are seemingly paradoxical, given clinical and physiological evidence suggesting that these systems share the same neural hardware.

These and many more issues should make the IPL an exciting field in which to work in the next several years.

I thank Dr. W. T. Newsome and R. H. Wurtz for providing Figure 14.

Address of R. A. Andersen as of 1 March 1987: Dept. of Brain and Cognitive Sciences, Massachusetts Institute of Technology, Cambridge, MA 02139.

REFERENCES

1. ACUÑA, C., F. GONZALEZ, AND R. DOMINGUEZ. Sensorimotor unit activity related to intention in the pulvinar of behaving *Cebus apella* monkeys. *Exp. Brain Res.* 52: 411-422, 1983.
2. ALBRIGHT, T. D. Direction and orientation selectivity of neurons in visual area MT of the macaque. *J. Neurophysiol.* 52: 1106-1130, 1984.
3. ALBRIGHT, T. D., R. DESIMONE, AND C. G. GROSS. Columnar organization of directionally selective cells in visual area MT of the macaque. *J. Neurophysiol.* 51: 16-31, 1984.
4. ALLMAN, J. M., J. F. BAKER, W. T. NEWSOME, AND S. E. PETERSEN. Visual topography and function: cortical visual areas in the owl monkey. In: *Cortical Sensory Organization. Multiple Visual Areas*, edited by C. N. Woolsey. Clifton, NJ: Humana, 1978, vol. 2, p. 171-185.
5. ALLMAN, J., F. MIEZEN, AND E. MCGUINNESS. Stimulus specific responses from beyond the classical receptive field: neurophysiological mechanism for local-global comparisons in visual neurons. *Annu. Rev. Neurosci.* 8: 407-430, 1985.
6. ANDERSEN, R. A. The neurobiological basis of spatial cognition: role of the parietal lobe. In: *Spatial Cognition: Brain Bases and Development*, edited by J. Stiles-Davis, M. Kritchevsky, and U. Bellugi. Chicago, IL: Univ. of Chicago Press, in press.
7. ANDERSEN, R. A., C. ASANUMA, AND W. M. COWAN. Callosal and prefrontal associational projecting cell populations in area 7a of the macaque monkey: a study using retrogradely transported fluorescent dyes. *J. Comp. Neurol.* 232: 443-455, 1985.
8. ANDERSEN, R. A., G. K. ESSICK, AND R. M. SIEGEL. Encoding of spatial location by posterior parietal neurons. *Science Wash. DC* 230: 456-458, 1985.
- 8a. ANDERSEN, R. A., G. K. ESSICK, AND R. M. SIEGEL. Neurons of area 7 activated by both visual stimuli and oculomotor behavior. *Exp. Brain Res.* In press.
9. ANDERSEN, R. A., AND V. B. MOUNTCASTLE. The influence of the angle of gaze upon the excitability of the light-sensitive neurons of the posterior parietal cortex. *J. Neurosci.* 3: 532-548, 1983.
10. ANDERSEN, R. A., R. M. SIEGEL, G. K. ESSICK, AND C. ASANUMA. Subdivision of the inferior parietal lobule and dorsal prelunate gyrus of macaque by connective and functional criteria (Abstract). *Invest. Ophthalmol. Visual Sci.* 23: 266, 1985.
11. ASANUMA, C., R. A. ANDERSEN, AND W. M. COWAN. The thalamic relations of the caudal inferior parietal lobule and the lateral prefrontal cortex in monkeys: divergent cortical projections from cell clusters in the medial pulvinar nucleus. *J. Comp. Neurol.* 241: 357-381, 1985.
12. BALEDYER, C., AND F. MAUGUIERE. The duality of the cin-

- gulate gyrus in monkey. Neuroanatomical study and functional hypothesis. *Brain* 103: 525-554, 1980.
13. BALEYDIER, C., AND F. MAUGUIERE. Anatomical evidence for medial pulvinar connections with the posterior cingulate cortex, the retrosplenial area, and the posterior parahippocampal gyrus in monkeys. *J. Comp. Neurol.* 232: 219-228, 1985.
 14. BALLARD, D. H. Cortical connections and parallel processing: structure and function. *Behav. Brain Sci.* 9: 90-91, 1986.
 15. BARBAS, H., AND M.-M. MESULAM. Organization of afferent input to subdivisions of area 8 in the rhesus monkey. *J. Comp. Neurol.* 200: 407-431, 1981.
 16. BARBUR, J. L., K. H. RUDDOCK, AND V. A. WATERFIELD. Human visual responses in the absence of the geniculocalcarine projection. *Brain* 103: 905-928, 1980.
 17. BENDER, D. B. Retinotopic organization of macaque pulvinar. *J. Neurophysiol.* 46: 672-693, 1981.
 18. BENEVENTO, L. A., AND B. DAVIS. Topographic projections of the prestriate cortex to the pulvinar nuclei in the macaque monkey: an autoradiographic study. *Exp. Brain Res.* 30: 405-424, 1977.
 19. BENEVENTO, L. A., AND J. H. FALLON. The ascending projections of the superior colliculus in the rhesus monkey (*Macaca mulatta*). *J. Comp. Neurol.* 160: 339-362, 1975.
 20. BENEVENTO, L. A., AND J. MILLER. Visual responses of single neurons in the caudal lateral pulvinar of the macaque monkey. *J. Neurosci.* 11: 1268-1278, 1981.
 24. BENEVENTO, L. A., AND M. REZAK. The cortical projections of the inferior pulvinar and adjacent lateral pulvinar in the rhesus monkey (*Macaca mulatta*): an autoradiographic study. *Brain Res.* 108: 1-24, 1976.
 25. BENEVENTO, L. A., M. REZAK, AND R. SANTOS-ANDERSON. An autoradiographic study of the projections of the pretectum in the rhesus monkey (*Macaca mulatta*): evidence of sensorimotor links to the thalamus and oculomotor nuclei. *Brain Res.* 127: 197-218, 1977.
 26. BENEVENTO, L. A., AND G. P. STANDAGE. The organization of projections of the retinorecipient and nonretinorecipient nuclei of the pretectal complex and layers of the superior colliculus to the lateral pulvinar and medial pulvinar in the macaque monkey. *J. Comp. Neurol.* 217: 307-336, 1983.
 27. BENSON, D. F., AND M. I. BARTON. Disturbances in constructional ability. *Cortex* 6: 14-46, 1970.
 28. BIOULAC, B., AND Y. LAMARRE. Activity of postcentral cortical neurons of the monkey during conditioned movements of a deafferented limb. *Brain Res.* 172: 427-437, 1979.
 29. BISIACH, E., AND C. LUZZATTI. Unilateral neglect of representational space. *Cortex* 14: 129-133, 1978.
 30. BISIACH, E., C. LUZZATTI, AND D. PERANI. Unilateral neglect, representational schema and consciousness. *Brain* 102: 609-618, 1979.
 31. BLUM, B. Enhancement of visual responses of area 7 neurons by electrical preconditioning stimulation of LP-pulvinar nuclei of the monkey. *Exp. Brain Res.* 59: 434-440, 1985.
 32. BRAIN, W. R. Visual disorientation with special reference to lesions of the right cerebral hemisphere. *Brain* 64: 244-272, 1941.
 33. BRIDGEMAN, B., AND L. STARK. Omnidirectional increase in threshold for image shifts during saccadic eye movements. *Percept. Psychophys.* 25: 241-243, 1979.
 34. BRODAL, P. Principles of organization of the monkey corticopontine projection. *Brain* 148: 214-218, 1978.
 35. BRODMANN, K. Beitrage zur histologischen Lokalisation der Grosshirnrinde. Dritte Mitteilung: die Rindenfelder der niederen Affen. *J. Psychol. Neurol.* 4: 177-226, 1905.
 36. BRODMANN, K. Beitrage zur histologischen Lokalisation der Grosshirnrinde. Sechste Mitteilung: die Cortex gliederung des Menschen. *J. Psychol. Neurol.* 10: 231-246, 1907.
 37. BRODY, B. A., AND K. H. PRIBRAM. The role of frontal and parietal cortex in cognitive processing: tests of spatial and sequential functions. *Brain* 101: 607-633, 1978.
 - 37a. BRUCE, C. J., R. DESIMONE, AND C. G. GROSS. Properties of neurons in a visual polysensory area in the superior temporal sulcus of the macaque. *J. Neurophysiol.* 46: 369-384, 1981.
 38. BUSHNELL, M. C., M. E. GOLDBERG, AND D. L. ROBINSON. Behavioral enhancement of visual responses in monkey cerebral cortex. I. Modulation in posterior parietal cortex related to selective visual attention. *J. Neurophysiol.* 46: 755-772, 1981.
 39. CAMINITI, R., AND A. SBRICCOLI. The callosal system of the superior parietal lobule in the monkey. *J. Comp. Neurol.* 237: 85-99, 1985.
 40. CHALUPA, L. M., R. S. COYLE, AND D. B. LINDSLEY. Effect of pulvinar lesions on visual pattern discrimination in monkeys. *J. Neurophysiol.* 39: 354-369, 1976.
 41. CHAPMAN, C. E., G. SPIDALIERI, AND Y. LAMARRE. Discharge properties of area 5 neurones during arm movements triggered by sensory stimuli in the monkey. *Brain Res.* 309: 63-78, 1984.
 42. CHAVIS, D. A., AND D. M. PANDYA. Further observation on corticofrontal connections in the rhesus monkey. *Brain Res.* 117: 369-386, 1976.
 43. COLBY, C. L., R. GATTASS, C. R. OLSON, AND C. G. GROSS. Cortical afferents to visual areas in the macaque. *Soc. Neurosci. Abstr.* 9: 152, 1983.
 44. CRICK, F. Function of the thalamic reticular complex: the searchlight hypothesis. *Proc. Natl. Acad. Sci. USA* 81: 4586-4590, 1984.
 45. CRITCHLEY, M. *The Parietal Lobes*. New York: Hafner, 1953.
 46. DENNY-BROWN, D., AND B. BANKER. Armorphosynthesis from left parietal lesion. *Arch. Neurol. Psychiatry* 71: 302-313, 1954.
 47. DE RENZI, E. Memory disorders following focal neocortical damage. *Philos. Trans. R. Soc. Lond. B Biol. Sci.* 298: 73-83, 1982.
 48. DE RENZI, E., P. FAGLIONI, AND P. PREVIDI. Spatial memory and hemispheric locus of lesion. *Cortex* 13: 424-433, 1977.
 49. DE RENZI, E., P. FAGLIONI, AND G. SCOTTI. Hemispheric contribution to exploration of space through the visual and tactile modality. *Cortex* 6: 191-203, 1970.
 50. DE RENZI, E., P. FAGLIONI, AND P. VILLA. Topographical amnesia. *J. Neurol. Neurosurg. Psychiatry* 40: 498-505, 1977.
 51. DESIMONE, R., T. D. ALBRIGHT, C. G. GROSS, AND C. BRUCE. Stimulus-selective properties of inferior temporal neurons in the macaque. *J. Neurosci.* 4: 2051-2062, 1984.
 52. DIVAC, I., J. H. LAVAIL, P. RAKIC, AND K. R. WINSTON. Heterogeneous afferents to the inferior parietal lobule of the rhesus monkey revealed by the retrograde transport method. *Brain Res.* 123: 197-207, 1977.
 53. DOW, B. M. Functional classes of cells and their laminar distribution in monkey visual cortex. *J. Neurophysiol.* 37: 927-946, 1974.
 54. DUBNER, R., AND S. M. ZEKI. Response properties and receptive fields of cells in an anatomically defined region of the superior temporal sulcus in the monkey. *Brain Res.* 35: 528-532, 1971.
 55. DUNCKER, K. Über induzierte Bewegung. *Psychol. Forsch.* 12: 180-259, 1929.
 - 55a. DURSTELER, M. R., R. H. WURTZ, W. T. NEWSOME, AND A. MIKIMI. Deficits in pursuit eye movements following ibotenic acid lesions of the foveal representation of area MT of macaque monkey. *Soc. Neurosci. Abstr.* 10: 475, 1984.
 56. ETTLINGER, G., AND J. E. KALSBECK. Changes in tactile discrimination and in visual reaching after successive and simultaneous bilateral posterior parietal ablations in the monkey. *J. Neurol. Neurosurg. Psychiatry* 25: 256-268, 1962.
 57. ETTLINGER, G., E. WARRINGTON, AND O. L. ZANGWILL. A further study of visual-spatial agnosia. *Brain* 80: 335-361, 1957.
 58. FAUGIER-GRIMAUD, S., C. FRENOIS, AND D. G. STEIN. Effects of posterior parietal lesions on visually guided behavior in monkeys. *Neuropsychologia* 16: 151-168, 1978.
 59. FESTINGER, L., H. A. SEDGWICK, AND J. D. HOLTZMAN. Visual perception during smooth pursuit eye movements. *Vision Res.* 16: 1377-1386, 1976.
 60. FRIEDMAN, D. P., E. G. JONES, AND H. BURTON. Representation pattern in the second somatic sensory area of the monkey cerebral cortex. *J. Comp. Neurol.* 192: 21-41, 1980.

61. FUSTER, J. M. *The Prefrontal Cortex: Anatomy, Physiology, and Neuropsychology of the Frontal Lobe*. New York: Raven, 1980.
62. FUSTER, J. M. Prefrontal cortex in motor control. In: *Handbook of Physiology. The Nervous System. Motor Control*, edited by V. B. Brooks. Bethesda, MD: Am. Physiol. Soc., 1981, sect. 1, pt. 2, vol. 2, chapt. 25, p. 1149-1178.
63. GLICKSTEIN, M., J. L. COHEN, B. DIXON, A. GIBSON, M. HOLLINS, E. LABOSSIERE, AND F. ROBINSON. Corticopontine visual projections in macaque monkeys. *J. Comp. Neurol.* 190: 209-229, 1980.
64. GLICKSTEIN, M., AND J. MAY. Visual control of movement: the circuits which link visual to motor areas of the brain with special reference to the visual input to the pons and cerebellum. In: *Contributions to Sensory Physiology*, edited by W. D. Neff. New York: Academic, 1982, vol. 7, p. 103-145.
65. GLICKSTEIN, M., J. MAY, AND B. MERCER. Cortico-pontine projection in the macaque: the distribution of labeled cortical cells after large injections of horseradish peroxidase in the pontine nuclei. *J. Comp. Neurol.* 235: 343-359, 1985.
66. GOLDBERG, M. E., C. J. BRUCE, L. UNGERLEIDER, AND M. MISHKIN. Role of the striate cortex in generation of smooth pursuit eye movements (Abstract). *Ann. Neurol.* 12: 113, 1982.
67. GROSS, C. G. Visual functions of inferotemporal cortex. In: *Handbook of Sensory Physiology. Visual Centers in the Brain*, edited by R. Jung. Berlin: Springer-Verlag, 1972, vol. VII, pt. 3B, p. 451-485.
68. GROSS, C. G., C. J. BRUCE, R. DESIMONE, J. FLEMING, AND R. GATTASS. Cortical visual areas of the temporal lobe: three areas in the macaque. In: *Multiple Visual Areas*, edited by C. N. Woolsey. Clifton, NJ: Humana, 1981, vol. 2, p. 187-216.
69. HALLETT, P. E., AND A. D. LIGHTSTONE. Saccadic eye movements toward stimuli triggered by prior saccades. *Vision Res.* 16: 99-106, 1976.
70. HANSEN, R. M., AND A. A. SKAVENSKI. Accuracy of eye position information for motor control. *Vision Res.* 17: 919-926, 1977.
71. HARTING, J. K., M. F. HUERTA, A. J. FRANKFURTER, N. L. STROMINGER, AND G. J. ROYCE. Ascending pathways from the monkey superior colliculus: an autoradiographic analysis. *J. Comp. Neurol.* 192: 853-882, 1980.
72. HARTJE, W., AND G. ETTLINGER. Reaching in light and dark after unilateral posterior parietal ablations in the monkey. *Cortex* 9: 346-354, 1974.
73. HECAEN, H., AND J. AJURIAGUERRA. Balint's syndrome (psychic paralysis of visual fixation) and its minor forms. *Brain* 77: 373-400, 1954.
74. HECAEN, H., W. PENFIELD, C. BERTRAND, AND R. MALINO. The syndrome of apractognosia due to lesions of the minor cerebral hemisphere. *Arch. Neurol. Psychiatry* 75: 400-434, 1956.
- 74a. HEDREEN, J. C., AND T. C. T. YIN. Homotopic and heterotopic callosal afferents of caudal inferior parietal lobule in *Macaca mulatta*. *J. Comp. Neurol.* 197: 605-621, 1981.
75. HIER, D. B., J. MOUDLOCK, AND L. R. CAPLAN. Behavioral abnormalities after right hemisphere stroke. *Neurology* 33: 337-344, 1983.
76. HINTON, G. E. *Distributed Representations*. New York: Carnegie-Mellon Univ. Press, 1984. (Tech. Rep. CMU-CS-84-157.)
77. HOLMES, G. Disturbances of visual space perception. *Br. Med.* 2: 230-233, 1919.
78. HOLTZMAN, J. D., H. A. SEDGWICK, AND L. FESTINGER. Interaction of perceptually monitored and unmonitored efferent commands for smooth pursuit eye movements. *Vision Res.* 18: 1545-1555, 1978.
79. HYVÄRINEN, J. Regional distribution of functions in parietal association area 7 of the monkey. *Brain Res.* 206: 287-303, 1981.
- 79a. HYVÄRINEN, J. *The Parietal Cortex of Monkey and Man*. Berlin: Springer-Verlag, 1982.
80. HYVÄRINEN, J., AND A. PORANEN. Function of the parietal associative area 7 as revealed from cellular discharges in alert monkeys. *Brain* 97: 673-692, 1974.
81. HYVÄRINEN, J., AND Y. SHELEPIN. Distribution of visual and somatic functions in the parietal associative area 7 of the monkey. *Brain Res.* 169: 561-564, 1979.
82. JACOBSON, S., AND J. Q. TROJANOWSKI. Prefrontal granular cortex of the rhesus monkey. I. Intrahemispheric cortical afferents. *Brain Res.* 132: 209-233, 1977.
83. JONES, E. G., AND T. P. S. POWELL. An anatomical study of converging sensory pathways within the cerebral cortex of the monkey. *Brain* 93: 793-820, 1970.
84. JUNG, R. Neuropsychologie und er Neurophysiologie des Kontrast- und Formsehens in Zeichnung und Mulerei. In: *Psychopathologie Musischer Gestaltungen*, edited by H. H. Wieck. Stuttgart, FRG: Schattauer, 1974, p. 29-88.
85. KAAS, J. H., M. SUR, R. J. NELSON, AND M. MERZENICH. The postcentral somatosensory cortex: multiple representations of the body in primates. In: *Cortical Sensory Organization. Multiple Somatic Areas*, edited by C. N. Woolsey. Clifton, NJ: Humana, 1981, vol 1, p. 29-46.
86. KALASKA, J. F., R. CAMINITI, AND A. P. GEORGIOPOULIS. Cortical mechanisms related to the direction of two-dimensional arm movements: relations in parietal area 5 and comparison with motor cortex. *Exp. Brain Res.* 51: 247-260, 1983.
87. KASDON, D. L., AND S. JACOBSON. The thalamic afferents to the inferior parietal lobule of the rhesus monkey. *J. Comp. Neurol.* 177: 685-706, 1978.
88. KAWANO, K., M. SASAKI, AND M. YAMASHITA. Response properties of neurons in posterior parietal cortex of monkey during visual-vestibular stimulation. I. Visual tracking neurons. *J. Neurophysiol.* 51: 340-351, 1984.
89. KELLER, E. L., AND W. F. CRANDALL. Neuronal responses to optokinetic stimuli in pontine nuclei of behaving monkey. *J. Neurophysiol.* 49: 169-187, 1983.
90. KINSBOURNE, M., AND E. K. WARRINGTON. A disorder of simultaneous form perception. *Brain* 45: 461-486, 1962.
91. KUNZLE, H., AND K. AKERT. Efferent connections of cortical area 8 (frontal eye field) in *Macaca fascicularis*. A reinvestigation using the autoradiographic techniques. *J. Comp. Neurol.* 173: 147-164, 1977.
92. KUYPERS, H. G. J. M., M. K. SZWARCBART, M. MISHKIN, AND H. E. ROSVOLD. Occipitotemporal corticocortical connections in the rhesus monkey. *Exp. Neurol.* 11: 245-262, 1965.
93. LAMARRE, Y., G. SPIDALIERI, AND C. E. CHAPMAN. Activity of areas 4 and 7 neurons during movements triggered by visual, auditory, and somesthetic stimuli in the monkey: movement-related versus stimulus-related responses. *Exp. Brain Res. Suppl.* 10: 196-210, 1985.
94. LAMOTTE, R. H., AND C. ACUÑA. Defects in accuracy of reaching after removal of posterior parietal cortex in monkeys. *Brain Res.* 139: 309-326, 1978.
95. LANE, J. K. *The Modular Efferent Organization of the Inferior Parietal Lobule and Caudal Principal Sulcus for Their Callosal and Reciprocal Association Projections*. Baltimore, MD: Johns Hopkins Univ. Press, 1983. Dissertation.
96. LEICHNETZ, G. R. An intrahemispheric columnar projection between two cortical multisensory convergence areas (inferior parietal lobule and prefrontal cortex): an anterograde study in macaque using HRP gel. *Neurosci. Lett.* 18: 119-124, 1980.
97. LEINONEN, L., J. HYVÄRINEN, G. NYMAN, AND I. LINNANKOSKI. I. Functional properties of neurons in lateral part of associative area 7 in awake monkeys. *Exp. Brain Res.* 34: 299-320, 1979.
98. LEINONEN, L., AND G. NYMAN. II. Functional properties of cells in anterolateral part of area 7 associative face area of awake monkeys. *Exp. Brain Res.* 34: 321-333, 1979.
99. LISBERGER, S. G., AND A. F. FUCHS. Response of flocculus Purkinje cells to adequate vestibular stimulation in the alert monkey: fixation vs. compensatory eye movement. *Brain Res.* 69: 347-353, 1974.
100. LISBERGER, S. G., AND A. F. FUCHS. Role of primate flocculus during rapid behavioral modification of vestibuloocular reflex. I. Purkinje cell activity during visually guided horizontal

- smooth-pursuit eye movements and passive head rotation. *J. Neurophysiol.* 41: 733-763, 1978.
101. LIVINGSTONE, M. S., AND D. H. HUBEL. Anatomy and physiology of a color system in the primate visual cortex. *J. Neurosci.* 4: 309-356, 1984.
 - 101a. LUND, J. S., A. E. HENDRICKSON, M. P. OGREN, AND E. A. TOBIN. Anatomical organization of primate visual cortex area VII. *J. Comp. Neurol.* 202: 19-45, 1981.
 102. LYNCH, J. C. The functional organization of posterior parietal association cortex. *Behav. Brain Sci.* 3: 485-534, 1980.
 - 102a. LYNCH, J. C., C. ACUÑA, H. SAKATA, A. GEORGOPOULOS, AND V. B. MOUNTCASTLE. The parietal association areas and immediate extrapersonal space. *Annu. Meet. Soc. Neurosci., 3rd, 1973*, p. 244.
 103. LYNCH, J. C., A. M. GRAYBIEL, AND L. J. LOBECK. The differential projection of two cytoarchitectural subregions of the inferior parietal lobule of macaque upon the deep layers of the superior colliculus. *J. Comp. Neurol.* 235: 241-254, 1985.
 104. LYNCH, J. C., AND J. W. MCLAREN. The contribution of parieto-occipital association cortex to the control of slow eye movements. In: *Functional Basis of Ocular Motility Disorders*, edited by G. Lennerstrand, D. S. Zee, and E. L. Keller. Oxford, UK: Pergamon, 1982, p. 501-510.
 105. LYNCH, J. C., V. B. MOUNTCASTLE, W. H. TALBOT, AND T. C. T. YIN. Parietal lobe mechanisms for directed visual attention. *J. Neurophysiol.* 40: 362-389, 1977.
 106. LYNCH, J. C., T. C. T. YIN, W. H. TALBOT, AND V. B. MOUNTCASTLE. Parietal association cortex neurons active during hand and eye tracking of objects in immediate extrapersonal space. *Physiol.* 16: 384, 1973.
 107. MACK, A., AND J. BACHANT. Perceived movement of the afterimage during eye movements. *Percept. Psychophys.* 6: 379-384, 1969.
 108. MACKAY, D. M. Visual stability and voluntary eye movements. In: *Handbook of Sensory Physiology. Central Processing of Visual Information*, edited by R. Jung. Berlin: Springer-Verlag, 1973, vol. VII, pt. 3, p. 307-331.
 109. MATIN, L. Eye movements and perceived visual direction. In: *Handbook of Sensory Physiology. Visual Psychophysics*, edited by D. Jameson and L. Hurvich. Berlin: Springer-Verlag, 1972, vol. VII, pt. 4, p. 331-380.
 110. MAUNSELL, J. H. R., AND D. C. VAN ESSEN. The connections of the middle temporal visual area (MT) and their relationship to a cortical hierarchy in the macaque monkey. *J. Neurosci.* 3: 2563-2586, 1983.
 111. MAUNSELL, J. H. R., AND D. C. VAN ESSEN. Functional properties of neurons in middle temporal visual area of the macaque monkey. I. Selectivity for stimulus direction, speed, and orientation. *J. Neurophysiol.* 49: 1127-1147, 1983.
 - 111a. MAY, J. G., AND R. A. ANDERSEN. Different patterns of corticopontine projections from separate cortical fields within the inferior parietal lobule and dorsal prelunate gyrus of the macaque. *Exp. Brain Res.* 63: 265-278, 1986.
 112. MAYS, L. E., AND D. L. SPARKS. Dissociation of visual and saccade-related responses in superior colliculus neurons. *J. Neurophysiol.* 43: 207-232, 1980.
 113. MCFIE, J., AND O. L. ZANGWILL. Visual-constructive disabilities associated with lesions of the left cerebral hemisphere. *Brain* 83: 243-260, 1960.
 114. MENDOZA, J. E., AND R. K. THOMAS. Effects of posterior parietal and frontal neocortical lesions in the squirrel monkey. *J. Comp. Physiol. Psychol.* 89: 170-182, 1975.
 115. MESULAM, M.-M. A cortical network for directed attention and unilateral neglect. *Ann. Neurol.* 10: 309-325, 1981.
 116. MESULAM, M.-M., AND E. J. MUFSON. Insula of the old world monkey. III. Efferent cortical output and comments on function. *J. Comp. Neurol.* 212: 38-52, 1982.
 117. MESULAM, M.-M., G. W. VAN HOESSEN, D. N. PANDYA, AND N. GESCHWIND. Limbic and sensory connections of the inferior parietal lobule (area PG) in the rhesus monkey: a study with a new method for horseradish peroxidase histochemistry. *Brain Res.* 136: 393-414, 1977.
 118. MILES, F. A., AND J. H. FULLER. Visual tracking and the primate flocculus. *Science Wash. DC* 189: 1000-1002, 1975.
 119. MISHKIN, M. A memory system in the monkey. *Philos. Trans. R. Soc. Lond. B Biol. Sci.* 298: 85-95, 1982.
 120. MOFFETT, A., G. ETTLINGER, H. B. MORTON, AND M. F. PIERCY. Tactile discrimination performance in the monkey: the effect of ablation of various subdivisions of the posterior parietal cortex. *Cortex* 3: 59-96, 1967.
 121. MORAN, J., AND R. DESIMONE. Selective attention gates visual processing in extrastriate cortex. *Science Wash. DC* 229: 782-784, 1985.
 122. MOTTER, B. C., AND V. B. MOUNTCASTLE. The functional properties of the light-sensitive neurons of the posterior parietal cortex studied in waking monkeys: foveal sparing and opponent vector organization. *J. Neurosci.* 1: 3-26, 1981.
 - 122a. MOTTER, B. C., M. A. STEINMETZ, AND V. B. MOUNTCASTLE. Directional sensitivity of parietal visual neurons to moving stimuli depends upon the extent of the field traversed by the moving stimuli. *Soc. Neurosci. Abstr.* 11: 1011, 1985.
 123. MOUNTCASTLE, V. B., R. A. ANDERSEN, AND B. C. MOTTER. The influence of attentive fixation upon the excitability of the light-sensitive neurons of the posterior parietal cortex. *J. Neurosci.* 1: 1218-1235, 1981.
 124. MOUNTCASTLE, V. B., J. C. LYNCH, A. GEORGOPOULOS, H. SAKATA, AND C. ACUÑA. Posterior parietal association cortex of the monkey: command function for operations within extrapersonal space. *J. Neurophysiol.* 38: 871-908, 1975.
 125. MOUNTCASTLE, V. B., B. C. MOTTER, M. A. STEINMETZ, AND C. J. DUFFY. Looking and seeing: the visual functions of the parietal lobe. In: *Dynamic Aspects of Neocortical Function*, edited by G. M. Edelman, W. E. Gall, and W. M. Cowan. New York: Wiley, 1984, p. 159-194.
 126. MOVSHON, J. A., E. H. ADELSON, M. S. GIZZI, AND W. T. NEWSOME. The analysis of moving visual patterns. *Exp. Brain Res. Suppl.* 11: 117-151, 1985.
 127. MOVSHON, J. A., AND W. T. NEWSOME. Functional characteristics of striate cortical neurons projecting to MT in the macaque. *Soc. Neurosci. Abstr.* 10: 933, 1984.
 128. MUFSON, E. J., AND M.-M. MESULAM. Insula of the old world monkey. II. Afferent cortical input and comments on the claustrum. *J. Comp. Neurol.* 212: 23-37, 1982.
 129. MUFSON, E. J., AND M.-M. MESULAM. Thalamic connections of the insula in the rhesus monkey and comments on the paralimbic connectivity of the medial pulvinar nucleus. *J. Comp. Neurol.* 227: 109-120, 1984.
 130. MUSTAVI, M. J., A. J. FUCHS, AND J. WALLMAN. Smooth-pursuit-related units in the dorsolateral ponds of the rhesus macaque. *Soc. Neurosci. Abstr.* 10: 987, 1984.
 131. NEWSOME, W. T., R. H. WURTZ, M. R. DURSTELER, AND A. MIKAMI. The middle temporal visual area of the macaque monkey: deficits in visual motion processing following ibotenic acid lesions in MT. *J. Neurosci.* 5: 825-840, 1985.
 132. OGREN, M., AND A. HENDRICKSON. Pathways between striate cortex and subcortical regions in *Macaca mulatta* and *Saimiri sciureus*: evidence for a reciprocal pulvinar connection. *Exp. Neurol.* 53: 780-800, 1976.
 133. OGREN, M. P., AND A. E. HENDRICKSON. The distribution of pulvinar terminals in visual areas 17 and 18 of the monkey. *Brain Res.* 137: 343-350, 1977.
 134. OGREN, M. P., AND A. E. HENDRICKSON. The morphology and distribution of striate cortex terminals in the inferior and lateral subdivisions of the Macaca monkey pulvinar. *J. Comp. Neurol.* 188: 179-200, 1979.
 - 134a. OGREN, M. P., C. A. MATEER, AND A. R. WYLER. Alterations in visually related eye movements and following left pulvinar damage in man. *Neuropsychologia* 22: 187-196, 1984.
 135. OLSZEWSKI, J. *The Thalamus of the Macaca Mulatta. An Atlas for Use in the Stereotaxic Instrument*. Basel: Karger, 1952.
 136. PANDYA, D. N., P. DYE, AND N. BUTTERS. Efferent cortico-cortical projections of the prefrontal cortex in the rhesus monkey. *Brain Res.* 31: 35-46, 1971.
 137. PANDYA, D. N., AND H. G. J. M. KUYPERS. Cortico-cortical connections in the rhesus monkey. *Brain Res.* 13: 13-36, 1969.
 138. PANDYA, D. N., AND B. SELTZER. Intrinsic connections and architectonics of posterior parietal cortex in the rhesus monkey. *J. Comp. Neurol.* 204: 196-210, 1982.

139. PANDYA, D. N., G. W. VAN HOESEN, AND M.-M. MESULAM. Efferent connections of the cingulate gyrus in the rhesus monkey. *Exp. Brain Res.* 42: 319-330, 1981.
140. PANDYA, D. N., AND L. A. VIGNOLO. Intra- and interhemispheric projections of the precentral, premotor and arcuate areas in the rhesus monkey. *Brain Res.* 26: 217-233, 1971.
141. PANDYA, D. N., AND E. H. YETERIAN. Proposed neural circuitry for spatial memory in the primate brain. *Neuropsychologia* 22: 109-122, 1984.
142. PATERSON, A., AND O. L. ZANGWILL. Disorders of visual space perception associated with lesions of the right hemisphere. *Brain* 67: 331-358, 1944.
143. PEARSON, R. C. A., P. BRODAL, AND T. P. S. POWELL. The projection of the thalamus upon the parietal lobe in the monkey. *Brain Res.* 144: 143-148, 1978.
144. PERENIN, M. T., AND M. JEANNEROD. Visual function within the hemianopic field following early cerebral hemidecortication in man. I. Spatial localization. *Neuropsychologia* 16: 1-13, 1978.
145. PERRETT, D. I., E. T. ROLLS, AND W. CAAN. Visual neurons responsive to faces in the monkey temporal cortex. *Exp. Brain Res.* 47: 329-342, 1982.
146. PETERSEN, S. E., J. D. MORRIS, AND D. L. ROBINSON. Modulation of attentional behavior by injection of GABA-related drugs into the pulvinar of macaque. *Soc. Neurosci. Abstr.* 10: 475, 1984.
147. PETERSEN, S. E., D. L. ROBINSON, AND W. KEYS. A physiological comparison of the lateral pulvinar and area 7 in the behaving macaque. *Soc. Neurosci. Abstr.* 8: 681, 1982.
148. PETERSEN, S. E., D. L. ROBINSON, AND W. KEYS. Pulvinar nuclei of the behaving rhesus monkey: visual responses and their modulation. *J. Neurophysiol.* 54: 867-886, 1985.
149. PETRIDES, M., AND S. D. IVERSEN. Restricted posterior parietal lesions in the rhesus monkey and performance on visuospatial tasks. *Brain Res.* 161: 63-77, 1979.
150. PETRIDES, M., AND D. N. PANDYA. Projections to the frontal cortex from the posterior parietal region in the rhesus monkey. *J. Comp. Neurol.* 228: 105-116, 1984.
151. PIERCY, M., H. HECAEN, AND J. AJUVIAGUERRA. Constructional apraxia associated with unilateral cerebral lesions—left and right sided cases compared. *Brain* 83: 225-242, 1960.
152. POHL, W. Dissociation of spatial discrimination deficits following frontal and parietal lesions in monkeys. *J. Comp. Physiol. Psychol.* 82: 227-239, 1973.
153. POPPEL, E., R. HELD, AND D. FROST. Residual visual function after brain wounds involving the central visual pathways in man. *Nature Lond.* 243: 295-296, 1973.
154. POSNER, M. I. Orienting of attention. *Q. J. Exp. Psychol.* 32: 3-25, 1980.
- 154a. POSNER, M. I., C. R. R. SNYDER, AND B. J. DAVIDSON. Attention and the detection of signals. *J. Exp. Psychol.* 109: 160-174, 1980.
155. RATCLIFF, G., AND G. A. B. DAVIES-JONES. Defective visual localization in focal brain wounds. *Brain* 95: 49-60, 1972.
156. RATCLIFF, G., R. M. RIDLEY, AND G. ETLINGER. Spatial disorientation in the monkey. *Cortex* 13: 62-65, 1977.
157. REZAK, M., AND L. A. BENEVENTO. A comparison of the organization of the projections of the dorsal lateral geniculate nucleus, the inferior pulvinar and adjacent lateral pulvinar to primary visual cortex (area 17) in the macaque monkey. *Brain Res.* 167: 19-40, 1979.
158. RICHMOND, B. J., AND T. SATO. Visual responses of inferior temporal neurons are modified by attention to different stimulus dimensions. *Soc. Neurosci. Abstr.* 8: 812, 1982.
159. ROBINSON, C. J., AND H. BURTON. Organization of somatosensory receptive fields in cortical areas 7b, retroinsular postauditory and granular insula of *M. fascicularis*. *J. Comp. Neurol.* 192: 69-92, 1980.
160. ROBINSON, C. J., AND H. BURTON. Somatic submodality distribution within the second somatosensory (SII), 7b, retroinsular, postauditory, and granular insular cortical areas of *M. fascicularis*. *J. Comp. Neurol.* 192: 93-108, 1980.
161. ROBINSON, D. A. Oculomotor control signals. In: *Basic Mechanisms of Ocular Motility and Their Clinical Implications*, edited by G. Lennerstrand and P. Bach-y-Rita. Oxford, UK: Pergamon, 1975, p. 337-374.
162. ROBINSON, D. L., M. E. GOLDBERG, AND G. B. STANTON. Parietal association cortex in the primate: sensory mechanisms and behavioral modulations. *J. Neurophysiol.* 41: 910-932, 1978.
163. ROBINSON, D. L., J. D. MORRIS, AND S. E. PETERSEN. Cued visual behavior and the pulvinar of the awake macaque (Abstract). *Invest. Ophthalmol. Visual Sci.* 25: S33, 1984.
164. ROCKLAND, K. S., AND D. N. PANDYA. Laminar origins and terminations of cortical connections of the occipital lobe in the rhesus monkey. *Brain Res.* 179: 3-20, 1979.
165. ROLLS, E. T., D. PERRETT, S. J. THORPE, A. PUERTO, A. ROPER-HALL, AND S. MADDISON. Responses of neurons in area 7 of the parietal cortex to objects of different significance. *Brain Res.* 169: 194-198, 1979.
166. ROSE, J. E. The cellular structure of the auditory region of the cat. *J. Comp. Neurol.* 91: 409-440, 1949.
167. SAITO, H., M. YUKIO, K. TANAKA, K. HIKOSAKA, Y. FUKADA, AND E. IWAI. Integration of direction signals of image motion in the superior temporal sulcus of the macaque monkey. *J. Neurosci.* 6: 145-157, 1986.
168. SAKATA, H., H. SHIBUTANI, Y. ITO, AND K. TSURUGAI. Parietal cortical neurons responding to rotary movement of visual stimuli in space. *Exp. Brain Res.* 61: 658-663, 1986.
169. SAKATA, H., H. SHIBUTANI, AND K. KAWANO. Parietal neurons with dual sensitivity to real and induced movements of visual stimuli. *Neurosci. Lett.* 9: 165-169, 1978.
170. SAKATA, H., H. SHIBUTANI, AND K. KAWANO. Spatial properties of visual fixation neurons in posterior parietal association cortex of the monkey. *J. Neurophysiol.* 43: 1654-1672, 1980.
171. SAKATA, H., H. SHIBUTANI, AND K. KAWANO. Functional properties of visual tracking neurons in posterior parietal association cortex of the monkey. *J. Neurophysiol.* 49: 1364-1380, 1983.
172. SAKATA, H., H. SHIBUTANI, K. KAWANO, AND T. HARRINGTON. Neural mechanisms of space vision in the parietal association cortex of the monkey. *Vision Res.* 25: 453-464, 1985.
173. SAPER, C. B., AND F. PLUM. Disorders of consciousness. In: *Handbook of Clinical Neurology. Clinical Neuropsychology*, edited by J. A. M. Frederiks. Amsterdam: Elsevier, 1985, vol. 1, p. 107-128.
- 173a. SCHLAG-REY, M., AND J. SCHLAG. Visuomotor functions of central thalamus in monkey. I. Unit activity related to spontaneous eye movements. *J. Neurophysiol.* 51: 1149-1174, 1984.
174. SCHWARTZ, M. L., AND P. S. GOLDMAN-RAKIC. Single cortical neurones have axon collaterals to ipsilateral cortex in fetal and adult primates. *Nature Lond.* 299: 154-155, 1982.
175. SCHWARTZ, M. L., AND P. S. GOLDMAN-RAKIC. Callosal and intrahemispheric connectivity of the prefrontal association cortex in rhesus monkey: relation between intraparietal and principal sulcal cortex. *J. Comp. Neurol.* 226: 403-420, 1984.
176. SEAL, J., AND D. COMMENGES. A quantitative analysis of stimulus- and movement-related responses in the posterior parietal cortex of the monkey. *Exp. Brain Res.* 58: 144-153, 1985.
177. SEAL, J., C. GROSS, AND B. BIOULAC. Activity of neurons in area 5 during a simple arm movement in monkeys before and after deafferentation of the trained limb. *Brain Res.* 250: 229-243, 1982.
178. SEAL, J., C. GROSS, D. DOUDET, AND B. BIOULAC. Instruction-related changes of neuronal activity in area 5 during a simple forearm movement in the monkey. *Neurosci. Lett.* 36: 145-150, 1983.
179. SEDGWICK, H. A., AND L. FESTINGER. Eye movements, efference, and visual perception. In: *Eye Movements and Psychological Processes*, edited by R. A. Monty and J. W. Senders. New York: Halsted, 1976, p. 221-230.
180. SELTZER, B., AND D. N. PANDYA. Some cortical projections of the parahippocampal area in the rhesus monkey. *Exp. Neurol.* 50: 146-160, 1976.
181. SELTZER, B., AND D. N. PANDYA. Afferent cortical connections and architectonics of the superior temporal sulcus and sur-

- rounding cortex in the rhesus monkey. *Brain Res.* 149: 1-24, 1978.
182. SELTZER, B., AND D. N. PANDYA. Converging visual and somatic sensory cortical input to the intraparietal sulcus of the rhesus monkey. *Brain Res.* 192: 339-351, 1980.
 183. SELTZER, B., AND D. N. PANDYA. Further observations on parieto-temporal connections in the rhesus monkey. *Exp. Brain Res.* 55: 301-312, 1984.
 184. SELTZER, B., AND G. W. VAN HOESEN. A direct inferior parietal lobule projection to the presubiculum in the rhesus monkey. *Brain Res.* 179: 157-161, 1979.
 185. SEMMES, J., S. WEINSTEIN, L. GHENT, AND H. L. TEUBER. Correlates of impaired orientation in personal and extrapersonal space. *Brain* 86: 747-772, 1963.
 186. SHIBUTANI, H., H. SAKATA, AND J. HYVÄRINEN. Saccade and blinking evoked by microstimulation of the posterior parietal association cortex of the monkey. *Exp. Brain Res.* 55: 1-8, 1984.
 187. SIEGEL, R. M., R. A. ANDERSEN, G. K. ESSICK, AND C. ASANUMA. The functional and anatomical subdivision of the inferior parietal lobule. *Soc. Neurosci. Abstr.* 11: 1012, 1985.
 188. SIQUEIRA, E. B. The temporo-pulvinar connections in the rhesus monkey. *Arch. Neurol.* 13: 321-330, 1965.
 189. SIQUEIRA, E. B. The cortical connections of the nucleus pulvinaris of the dorsal thalamus in rhesus monkey. *Int. J. Neurol.* 8: 139-154, 1971.
 190. SKAVENSKI, A. A., AND R. M. HANSEN. Role of eye position information in visual space perception. In: *Eye Movements and the Higher Psychological Functions*, edited by J. W. Senders, D. F. Fisher, and R. A. Monty. New York: Halsted, 1978, p. 15-34.
 191. STANDAGE, G. P., AND L. A. BENEVENTO. The organization of connections between the pulvinar and visual area MT in the macaque monkey. *Brain Res.* 262: 288-294, 1983.
 192. STANTON, G. B., W. L. R. CRUCE, M. C. GOLDBERG, AND D. L. ROBINSON. Some ipsilateral projections to areas PF and PG of the inferior parietal lobule in monkeys. *Neurosci. Lett.* 6: 243-250, 1977.
 193. STEIN, J. F. Effects of parietal lobe cooling on manipulative behavior in the conscious monkey. In: *Active Touch—The Mechanism of Recognition of Objects by Manipulation. A Multidisciplinary Approach*, edited by G. Gorden. Oxford, UK: Pergamon, 1978, p. 79-90.
 194. SUZUKI, D. A., AND E. L. KELLER. Visual signals in the dorsolateral pontine nucleus of the alert monkey: their relationship to smooth-pursuit eye movements. *Exp. Brain Res.* 53: 473-478, 1984.
 195. SUZUKI, D. A., J. MAY, AND E. L. KELLER. Smooth-pursuit eye movement deficits with pharmacological lesions in monkey dorsolateral pontine nucleus. *Soc. Neurosci. Abstr.* 10: 58, 1984.
 196. TANAKA, K., K. HIKOSAKA, H. SAITO, M. YUKIE, Y. FUKADA, AND E. IWAI. Analysis of local and wide-field movements in the superior temporal visual areas of the macaque monkey. *J. Neurosci.* 6: 134-144, 1986.
 197. TEUBER, H. L. Space perception and its disturbances after brain injury in man. *Neuropsychologia* 1: 47-57, 1963.
 198. TROJANOWSKI, J. Q., AND S. JACOBSON. Medial pulvinar afferents to frontal eye fields in rhesus monkey demonstrated by horseradish peroxidase. *Brain Res.* 80: 395-411, 1974.
 199. TROJANOWSKI, J. Q., AND S. JACOBSON. Peroxidase labeled subcortical afferents to pulvinar in rhesus monkey. *Brain Res.* 97: 144-150, 1975.
 200. TROJANOWSKI, J. Q., AND S. JACOBSON. Areal and laminar distribution of some pulvinar cortical efferents in rhesus monkey. *J. Comp. Neurol.* 169: 371-392, 1976.
 201. UNGERLEIDER, L. G., AND B. A. BRODY. Extrapersonal spatial orientation: the role of posterior parietal, anterior frontal, and inferotemporal cortex. *Exp. Neurol.* 56: 265-280, 1977.
 202. UNGERLEIDER, L. G., AND C. A. CHRISTENSEN. Pulvinar lesions in monkeys produce abnormal eye movements during visual discrimination training. *Brain Res.* 136: 189-196, 1977.
 203. UNGERLEIDER, L. G., AND C. A. CHRISTENSEN. Pulvinar lesions in monkeys produce abnormal scanning of a complex visual array. *Neuropsychologia* 17: 493-501, 1979.
 204. UNGERLEIDER, L. G., AND R. DESIMONE. Cortical connections of visual area MT in the macaque. *J. Comp. Neurol.* 248: 190-222, 1986.
 205. UNGERLEIDER, L. G., R. DESIMONE, T. W. GALKIN, AND M. MISHKIN. Subcortical projections of area MT in the macaque. *J. Comp. Neurol.* 223: 368-386, 1984.
 206. UNGERLEIDER, L. G., T. W. GALKIN, AND M. MISHKIN. Visuo-topographic organization of projections from striate cortex to inferior and lateral pulvinar in rhesus monkey. *J. Comp. Neurol.* 217: 137-157, 1983.
 207. UNGERLEIDER, L. G., AND M. MISHKIN. Two cortical visual systems. In: *The Analysis of Visual Behavior*, edited by D. J. Ingle, M. A. Goodale, and R. J. W. Mansfield. Cambridge, MA: MIT Press, 1982, p. 549-586.
 208. VAN ESSEN, D. C. Visual areas of the mammalian cerebral cortex. *Ann. Rev. Neurosci.* 2: 227-263, 1979.
 209. VAN ESSEN, D. C. Functional organization of primate and visual cortex. In: *Cerebral Cortex*, edited by A. A. Peters and E. G. Jones. New York: Plenum, 1985, vol. 3, p. 259-329.
 210. VAN ESSEN, D. C., AND J. H. R. MAUNSELL. Two-dimensional maps of the cerebral cortex. *J. Comp. Neurol.* 191: 255-281, 1980.
 211. VAN ESSEN, D. C., J. H. R. MAUNSELL, AND J. L. BIXBY. The middle temporal visual area in the macaque: myeloarchitecture, connections, functional properties and topographic organization. *J. Comp. Neurol.* 199: 293-326, 1981.
 212. VOGT, C., AND O. VOGT. Allgemeine Ergebnisse unserer Hirnforschung. *J. Psychol. Neurol.* 25: 279-462, 1919.
 213. VON BONIN, G., AND P. BAILEY. *The Neocortex of Macaca Mulatta*. Urbana: Univ. of Illinois Press, 1947.
 214. VON ECONOMO, C. *The Cytoarchitectonics of the Human Cerebral Cortex*. London: Oxford Univ. Press, 1929.
 215. WEISKRANTZ, L., E. K. WARRINGTON, D. M. SANDERS, AND J. MARSHALL. Visual capacity in the hemianopic field following a restricted occipital ablation. *Brain* 97: 709-728, 1974.
 216. WILBRAND, H. *Die Seelenblindheit als Herderscheinung*. Wiesbaden, Germany: Bergmann, 1887.
 217. WURTZ, R. H., M. E. GOLDBERG, AND D. L. ROBINSON. Brain mechanisms of visual attention. *Sci. Am.* 246: 124-135, 1982.
 218. WURTZ, R. H., AND C. W. MOHLER. Enhancement of visual responses in monkey striate cortex and frontal eye fields. *J. Neurophysiol.* 39: 766-772, 1976.
 219. WURTZ, R. H., AND W. T. NEWSOME. Divergent signals encoded by neurons in extrastriate areas MT and MST during smooth pursuit eye movements. *Soc. Neurosci. Abstr.* 11: 1246, 1985.
 220. YETERIAN, E. H., AND D. N. PANDYA. Corticothalamic connections of the posterior parietal cortex in the rhesus monkey. *J. Comp. Neurol.* 237: 408-426, 1985.
 221. YIN, T. C. T., AND V. B. MOUNTCASTLE. Visual input to the visuomotor mechanisms of the monkey's parietal lobe. *Science Wash. DC* 197: 1381-1383, 1977.
 222. YIN, T. C. T., AND V. B. MOUNTCASTLE. Mechanisms of neural integration in the parietal lobe for visual attention. *Federation Proc.* 37: 2251-2257, 1978.
 223. ZEE, D. S., A. YAMAZAKI, P. H. BUTLER, AND G. GÜCER. Effects of ablation of flocculus and paraflocculus on eye movements in primate. *J. Neurophysiol.* 46: 878-899, 1981.
 224. ZEKI, S. M. Colour coding in rhesus monkey prestriate cortex. *Brain Res.* 53: 422-427, 1973.
 225. ZEKI, S. M. Functional organization of a visual area in the posterior bank of the superior temporal sulcus of the rhesus monkey. *J. Physiol. Lond.* 236: 549-573, 1974.
 226. ZEKI, S. M. The functional organization of projections from striate to prestriate visual cortex in the rhesus monkey. *Cold Spring Harbor Symp. Quant. Biol.* 40: 591-600, 1975.
 227. ZEKI, S. M. The representation of colours in the cerebral cortex. *Nature Lond.* 284: 412-418, 1980.
 228. ZIHL, J., AND D. VON CRAMON. The contribution of the 'second' visual system to directed visual attention in man. *Brain* 102: 835-856, 1979.